



Leica DMS300 User Manual

Contents

General Instructions	
General Instructions	5
Important Safety Notes	6
Symbols Used	7
Safety Instructions	8
Introduction	
Congratulations!	11
Standard Delivery	12
System Overview – Boom Stand Configuration	13
Overview of the Instrument	14
System Overview – Standard Column Configuration	15
Effective Displayed Section	16
Assembly	
Leica DMS300 swing-arm stand	18
Baseplate and Vertical Column	18
Safety Ring and Horizontal Arm	19
10" monitor	20
Microscope Carrier and Leica DMS300	21
Objective Installation	22
Installing the Leica Ring Light	23
Leica DMS300 with Incident Light Stand	25
Incident Light Base and Focusing Column	25
Microscope Carrier and Leica DMS300	26
10" monitor	27
Objective Installation	28
Illumination: Installing the Leica LED3000 RL	29
Installation	
HD Mode (Standalone)	32
Cables and Terminals, Activating HD Mode (Standalone)	32
PC Mode	33
Connecting a Computer, Installing Software, Activating PC Mode	33
Limitations in PC Mode	34
Startup procedure	
Leica DMS300	36
Switching on the Leica DMS300	36
Switching on the Illumination	37
Focusing, Adjusting the Resistance of the Focus Drive	38
Changing Magnification, Click-stop Feature	39
Remote control	40
"Pairing" the Leica DMS300 with a Remote Control	42
Configuring the Front Button or Footswitch	43



Contents (Continued)

Operation

HD Mode (Standalone)	46
Checking Cables and Terminals	46
Switching on the Leica DMS300	47
Information about SD Memory Cards	48
Capturing Images without a Computer	49
Displaying Images and Videos without a Computer	50
White Balance	51
PC Mode	52
Checking Cables, Terminals and Software	52
Switching on the Leica DMS300	53
Additional Use of a HD Monitor in PC Mode	54

User Menu

Calling up the User Menu	56
Automatic White Balance	57
MANUAL WHITE BALANCE	58
Exposure	59
Resolution	60
Camera Settings	62
User-Defined Settings	64
Setting the overlay (SETUP OVERLAY)	66
Configuring Predefined Illumination Scenarios	68

Service

Care, Maintenance, Contact Persons	70
Spare parts	73

Specifications

Technical Data	75
Optical data	78
Dimensional Drawings	79
Leica DMS300	79
Leica DMS300 with Incident Light Stand	80
Leica DMS300 with Swing-arm Stand	81



General Instructions



General Instructions

Safety concept

Before using your Leica microscope for the first time, please read the "Safety Concept" brochure included with your instrument. It contains additional information on handling and care.



Use in clean rooms

The Leica DMS300 digital microscope system can be used in clean rooms without any problems.

Cleaning

- Do not use any unsuitable cleaning agents, chemicals or techniques for cleaning.
- Never use chemicals to clean colored surfaces or accessories with rubberized parts. This could damage the surfaces, and specimens could be contaminated by abraded particles.
- In most cases, we can provide special solutions on request. Some products can be modified, and we can offer other accessories for use in clean rooms.

Servicing

- Repairs may only be carried out by Leica Microsystems-trained service technicians. Only original Leica Microsystems spare parts may be used.

Responsibilities of person in charge of instrument

- Ensure that the Leica microscope is operated, maintained and repaired by authorized and trained personnel only.



Important Safety Notes

Instructions for Use

You can find information on individual system components on the interactive CD-ROM together with all relevant user manuals in additional languages. Keep it in a safe place, and readily accessible to the user. User manuals and updates are also available for you to download and print from our website www.leica-microsystems.com.

This operating manual describes the special functions of the Leica DMS300 digital microscope system and contains important instructions for its operational safety, maintenance, and accessories.

The "Safety Concept" booklet contains additional safety information regarding the service work, requirements and the handling of the microscope, accessories and electrical accessories as well as general safety instructions.

To maintain the unit in its original condition and to ensure safe operation, the user must follow the instructions and warnings contained in these user manuals.





Symbols Used

Warning! Safety hazard!



This symbol indicates especially important information that is mandatory to read and observe.

Failure to comply can cause the following:

- Hazards to personnel
- Functional disturbances or damaged instruments

Warning of hazardous electrical voltage



This symbol indicates information that must be read and observed.

Failure to comply can cause the following:

- Hazards to personnel
- Functional disturbances or damaged instruments

Danger due to hot surface.



This symbol warns against touching hot surfaces, e.g. those of light bulbs.

Important information



This symbol indicates additional information or explanations that are intended to provide clarity.





Safety Instructions

Description

- The individual modules fulfill the highest requirements for observation and documentation with the Leica DMS300 digital microscope system.

Intended Use

- Refer to "Safety Concept" booklet

Non-intended use

- Refer to "Safety Concept" booklet

Never use the Leica DMS300 or its components for surgical procedures (such as eye surgery) since it is not intended for such use.

The instruments and accessories described in this User Manual have been tested for safety and potential hazards. The responsible Leica affiliate

must be consulted whenever the instrument is altered, modified or used in conjunction with non-Leica components that are outside of the scope of this manual!

Unauthorized alterations to the instrument or noncompliant use shall void all rights to any warranty claims.

Place of use

- Refer to "Safety Concept" booklet
- Electrical components must be placed at least 10 cm away from the wall and from flammable substances.
- Avoid large temperature fluctuations, direct sunlight and vibrations. These conditions can distort measurements and micrographic images.

- In warm and warm-damp climatic zones, the individual components require special care in order to prevent the build-up of fungus.

Responsibilities of person in charge of instrument

- Refer to "Safety Concept" booklet

Ensure that:

- The Leica DMS300 digital microscope system and accessories are operated, maintained and repaired by authorized and trained personnel only.
- All operators have read, understood and observe this User Manual, and particularly the safety regulations.





Safety Instructions (continued)

Repairs, service work

- Refer to "Safety Concept" booklet
- Only original Leica Microsystems spare parts may be used.
- Before opening the instruments, switch off the power and unplug the power cable.
- Avoid contact with powered electrical circuits, which can lead to injury.

Transport

- Use the original packaging for shipping or transporting the individual modules of the Leica DMS300 digital microscope system and the accessory components.
- In order to prevent damage from vibrations, disassemble all moving parts that (according to the user manual) can be assembled and disassembled by the customer and pack them separately.

Integration in third-party products

- Refer to "Safety Concept" booklet

Disposal

- Refer to "Safety Concept" booklet

Legal regulations

- Refer to "Safety Concept" booklet

EC Declaration of Conformity

- Refer to "Safety Concept" booklet

Health risks

Workplaces with microscopes facilitate and improve the viewing task, but they also impose high demands on the eyes and holding muscles of the user. Depending on the duration of uninterrupted work, asthenopia and musculoskeletal problems may occur. For this reason, appropriate measures for reduction of the workload must be taken:

- Optimal arrangement of workplace, work assignments and work flow (changing tasks frequently).
- Thorough training of the personnel, giving consideration to ergonomic and organizational aspects.

The ergonomic optics concept and the design of the Leica DMS300 digital microscope system aim to limit the strain on the user to the lowest possible level.





Introduction



Congratulations!

We congratulate you on purchasing the Leica DMS300 digital microscope system by Leica Microsystems. The special design of the Leica DMS300 makes it a universal tool for viewing microscopic specimens and capturing still images or even movies.

Real Full HD display

The integrated HDMI output allows the microscope image to be output to a high-definition (HD-capable) monitor, where the following resolutions are possible:

- 1920×1080 (Full HD). This resolution provides the best possible imaging performance on a Full HD-capable monitor.
- 1280×720 (HD ready). This resolution is suitable for display on monitors labeled "HD ready" or on smaller monitors with a 10" or 12" diagonal.

Leica Application Suite EZ

Your Leica DMS300 digital microscope system includes the "Leica Application Suite EZ" (LAS-EZ) software. It allows additional scenarios to be implemented in which an HD monitor and computer monitor can even be used together. This means you will be perfectly equipped for any situation, including: Working on a computer, during presentations, training sessions, trade show appearances, during materials testing and more.

If you want to perform advanced image analyses, the Leica Application Suite (LAS Core) and countless (optionally available) LAS modules are available.

User-friendly even in the smallest detail

Like every digital camera, the Leica DMS300's integrated camera reacts differently to different light sources. However, the white balance is matched to LED illuminators from Leica at the factory. This means that if you use a Leica LED illuminator, you automatically obtain the best results!



Standard Delivery

Standard delivery

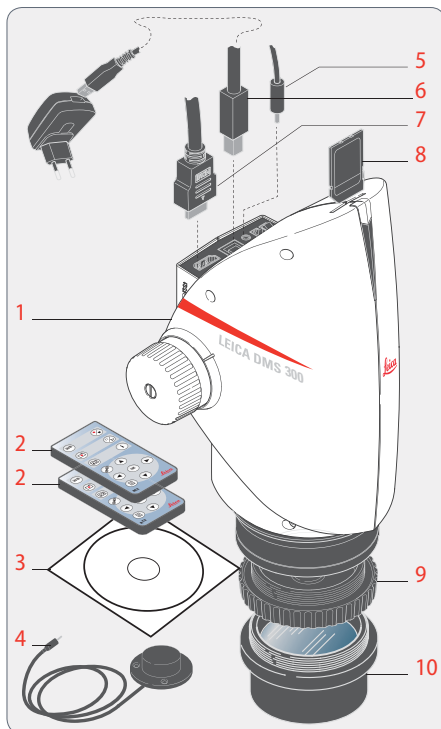

The Leica DMS300 digital microscope system's standard delivery includes:

- 1 *Digital Microscope System Leica DMS300*
- 2 *2 remote control units, with battery*
- 3 *"Leica Application Suite EZ (LAS-EZ)" software DVD*
- 4 *Hand/footswitch*
- 5 *Connection for footswitch*
- 6 *USB cable, for connecting to a computer or to a power supply unit for supplying power*
- 7 *HDMI cable, for connecting to an HD monitor*
- 8 *SD memory card*
- 9 *Protective cover*
- 10 *Objective*

 Additional information about working on the computer and with Leica Application Suite EZ is provided in the software's online help.

Various functions can be assigned to the hand-switch/footswitch (such as taking individual pictures, white balance).

System Overview – Boom Stand Configuration

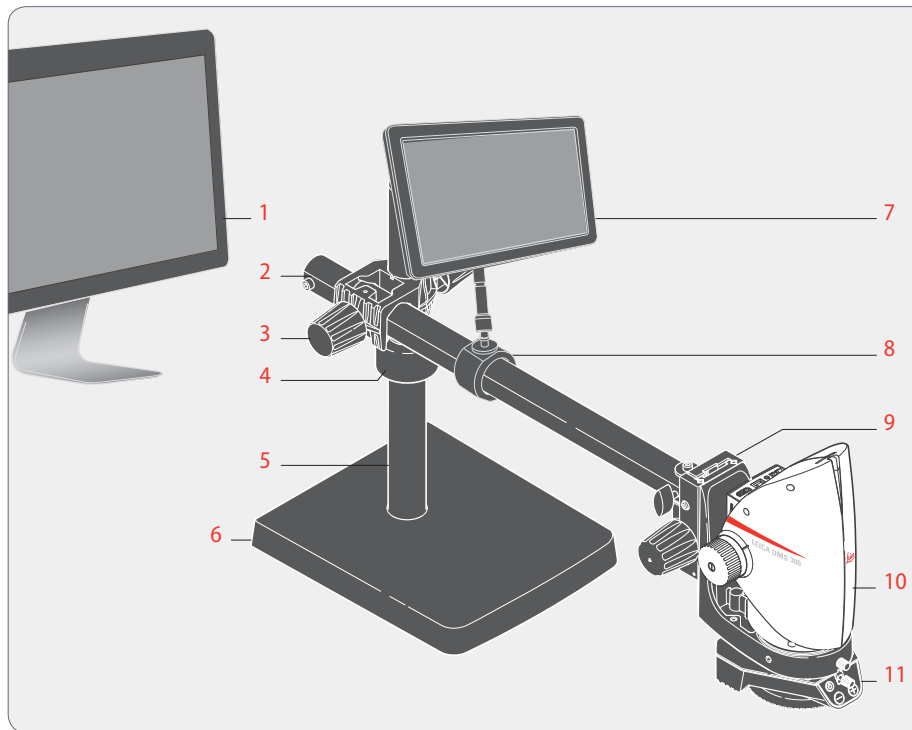

This overview shows the Leica DMS300 in an example application with additional components.

- 1 *HD monitor or computer with LAS EZ software*
- 2 *Horizontal arm*
- 3 *Cross-member*
- 4 *Safety ring*
- 5 *Column*
- 6 *Baseplate*
- 7 *10" monitor*
- 8 *Monitor holder*
- 9 *Microscope carrier*
- 10 *Leica DMS300*
- 11 *Leica ring light illuminator*



Overview of the Instrument

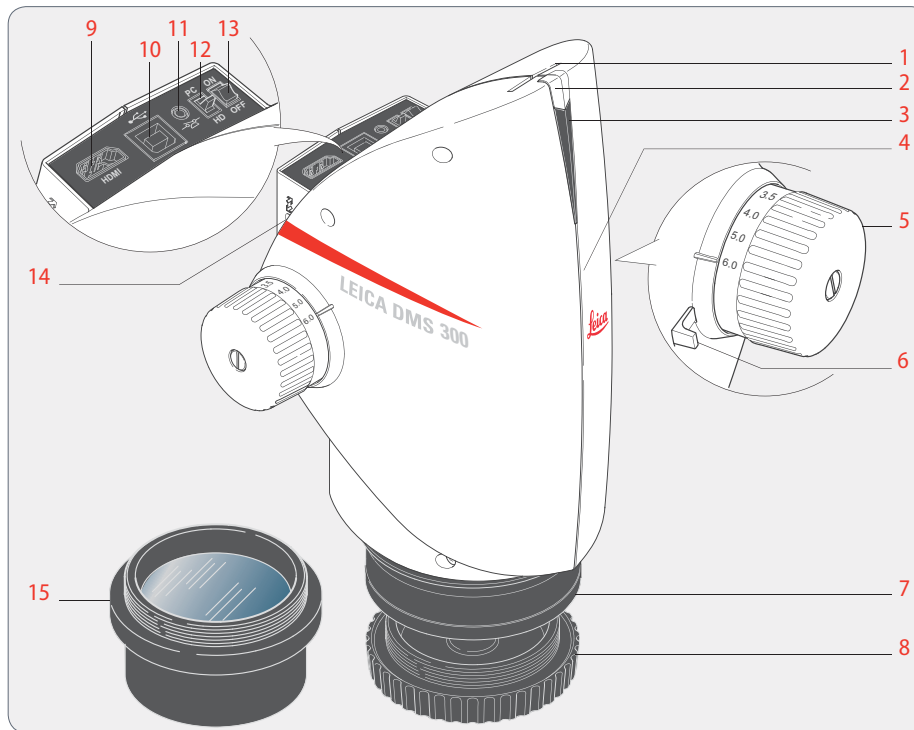

- 1 Card holder for SD card
- 2 Front button
- 3 Status light
- 4 IR receiver, for remote control
- 5 Zoom knob
- 6 Click-stop slider
- 7 Leica DMS300 mounting fixture in the microscope carrier
- 8 Protective cover
- 9 HDMI connection
- 10 USB connection
- 11 Connection for footswitch
- 12 Mode switch, for PC or HD mode
- 13 On/off switch
- 14 Reset button
- 15 Objective



System Overview – Standard Column Configuration

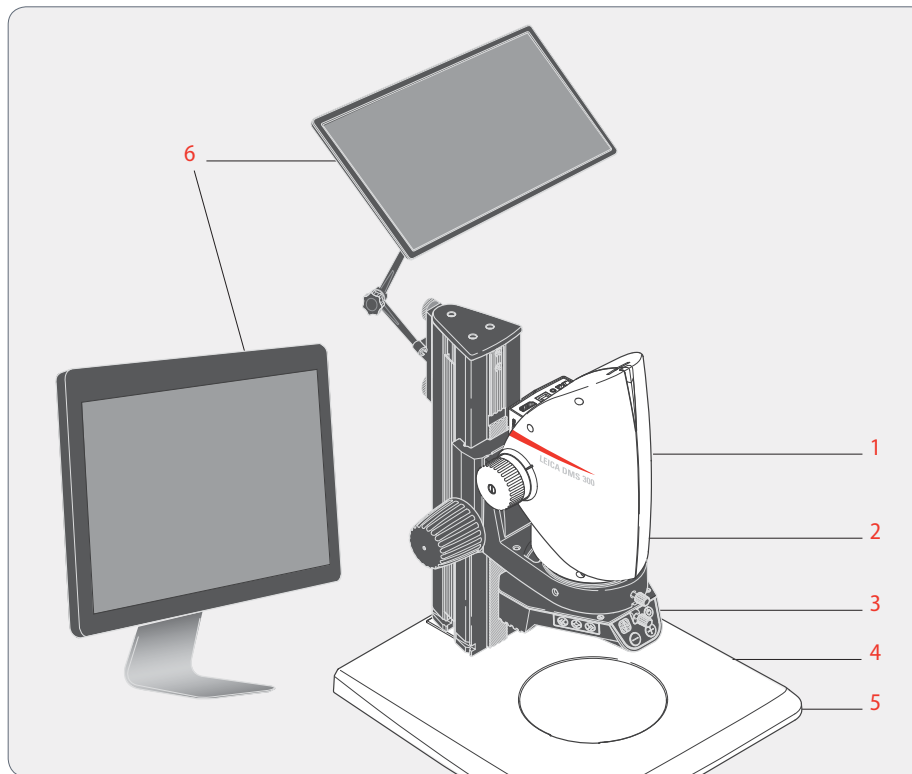

This overview shows the Leica DMS300 in an example application with additional components.

- 1 *Leica DMS300*
- 2 *Microscope carrier*
- 3 *Illumination*
- 4 *Focusing column*
- 5 *Baseplate*
- 6 *HD monitor or computer with LAS software*



Effective Displayed Section

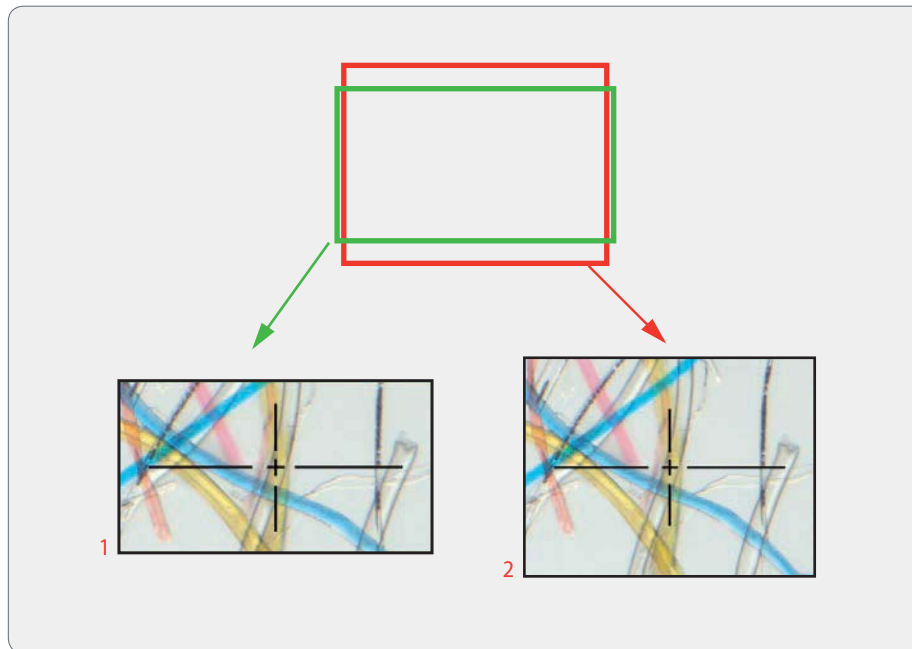

i The live image on the HD monitor and the final captured image may not show the same section depending on the sensor size in the microscope.

- 1 Live image in 16:9 format, displayed on the HD monitor
- 2 Captured image in 4:3 format, displayed on the computer or saved to an SD card.



Assembly



Leica DMS300 swing-arm stand

Baseplate and Vertical Column

Instructions for safe assembly



Due to the heavy weight of the baseplate, improper use can cause injuries or damage to the surrounding area. For safety reasons, use two people for this part of the setup.

Assembling the column

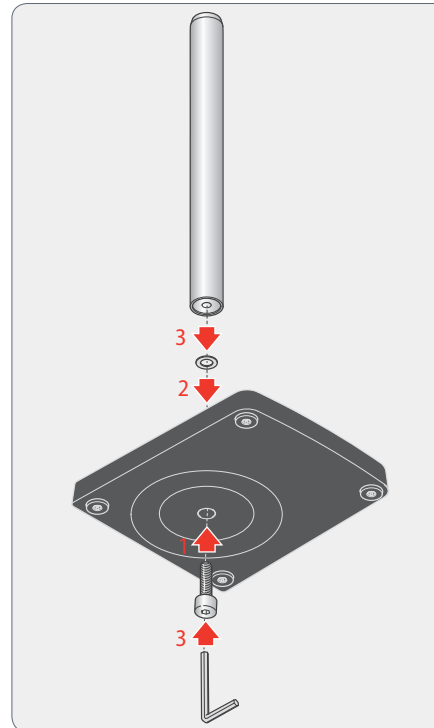

1. Push the tapping screw through the baseplate from below.
2. Fit the serrated lock washer onto the screw.
3. Install the vertical column on the base plate using the screw.



Safety Ring and Horizontal Arm

Installing the Safety Ring

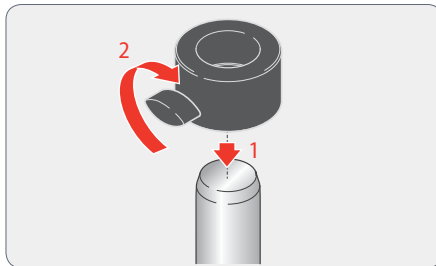

1. Push the safety ring over the column.
2. Securely tighten the clamping screw.

 The safety ring is the most important safety element of the entire configuration. It protects the horizontal arm from accidentally falling down.

Mounting the horizontal arm

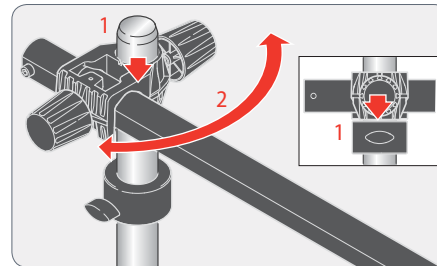

1. Push the cross-member with the horizontal arm over the column so that the cross-member lies securely on the safety ring.
2. You can now rotate the horizontal arm in any direction desired.

 The swing-arm stand is designed so that the Leica DMS300 can be moved as desired.

Fastening the horizontal arm

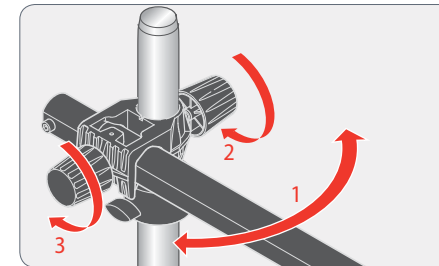

1. Rotate the horizontal arm into a secure position.
2. Carefully tighten the clamping screw on the cross-member to prevent the joint on the column from rotating.
3. Tighten the clamping screw to prevent the arm from extending.

 For safety reasons, you should fasten the horizontal arm in place when you leave your workstation.





10" monitor

Install on the horizontal arm

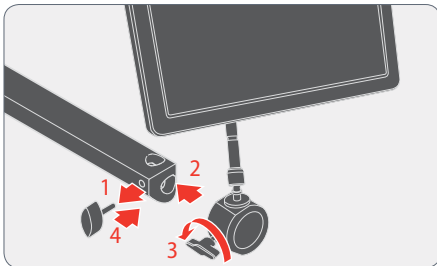

1. Remove the clamping screw.
2. Install the monitor holder on the horizontal arm.
3. Fasten the monitor holder to the clamping screw.
4. Reinstall the clamping screw.

Install on the vertical arm

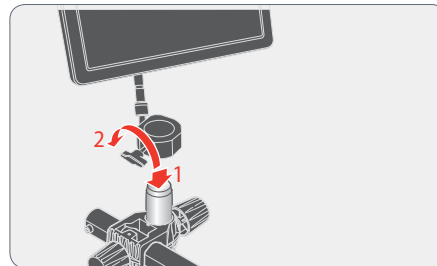

1. Install the monitor holder on the vertical arm.
2. Fasten the monitor holder to the clamping screw.





Microscope Carrier and Leica DMS300

Assembling the microscope carrier

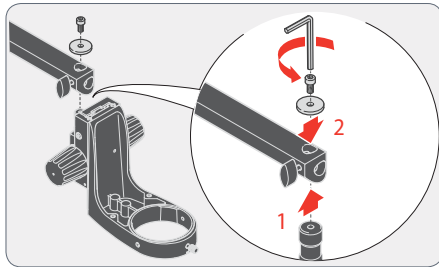

1. Insert the connecting pin from below into the bore of the horizontal arm.
2. Fasten the microscope carrier in place using the washer and safety screw.

Assembling the Leica DMS300

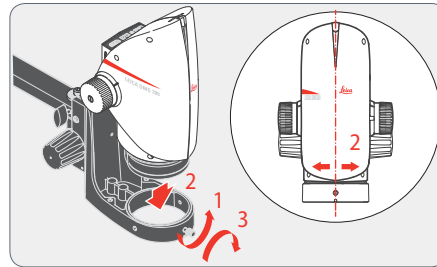

1. Unscrew the clamping screw.
2. Place the Leica DMS300 in the microscope carrier so that the notch in the microscope housing and the lower clamping screw overlap.
3. Fasten the microscope in place using the clamping screw.

Free movement of the microscope

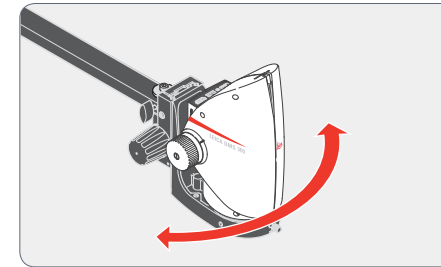

The microscope can be rotated freely together with the microscope carrier.





Objective Installation

Instructions for safe assembly

 Hold the 0.8× objective firmly during assembly and disassembly so that it does not fall onto the stage plate. Remove all specimens from the stage plate first.

Assembly

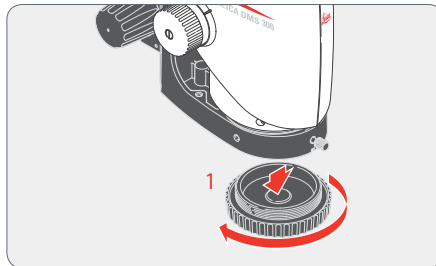

1. Remove the protective cap on the optics carrier by turning it.

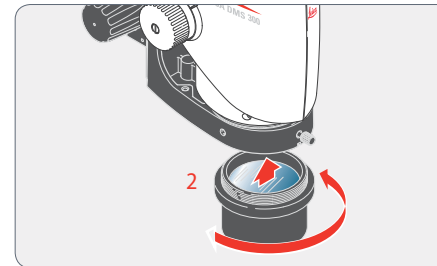

2. Screw the objective into the optics carrier.





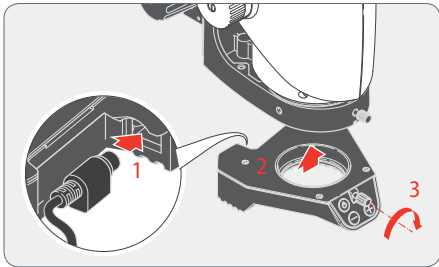

Installing the Leica Ring Light

Assembly of the Leica ring light illuminator

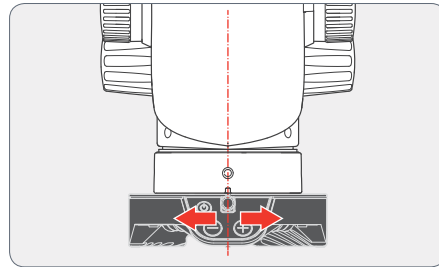

1. Connect the external power supply unit to the Leica ring light illuminator.
2. Attach the Leica ring light illuminator to the objective from below.
3. Tighten the locking screw.



 Ensure that the locking screw of the illuminator and the locking screw of the optics carrier are on a straight line.

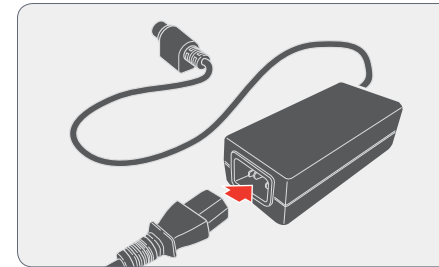

Connect the power supply to the power cable.





Illumination: Leica ring light illuminator (continued)

Assembly of the diffuser

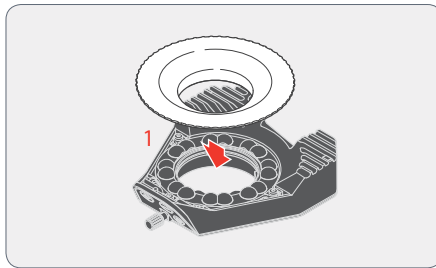

1. The diffuser is attached and screwed in below the ring light illuminator.

 We recommend assembling the diffuser on the Leica ring light illuminator on a table in reverse and then mounting them on the objective together.



Leica DMS300 with Incident Light Stand

Incident Light Base and Focusing Column

General Notes

 This chapter shows an example of assembly of the Leica DMS300 on an incident light base. Images and descriptions may vary when using another incident light base.

Assembling the column

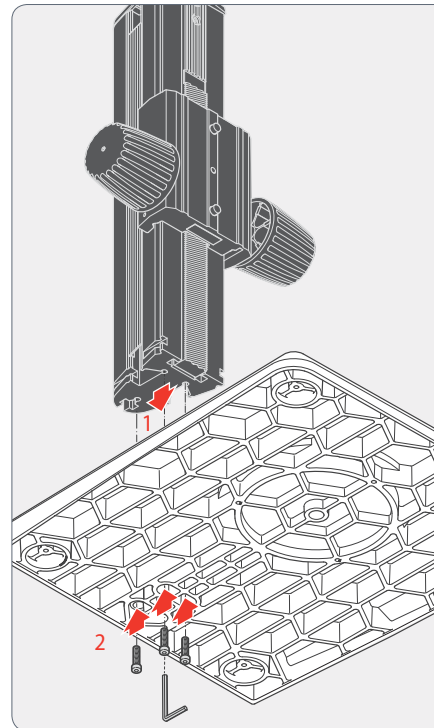

1. Take the three provided screws out of the packaging.
2. Install the incident light base on the column using the three screws.





Microscope Carrier and Leica DMS300

Assembling the microscope carrier

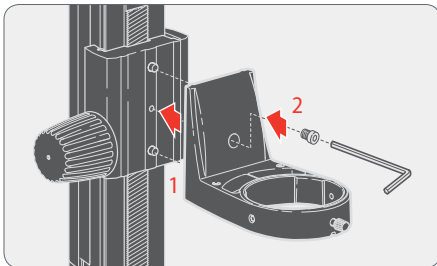

1. Fasten the microscope carrier to the column using the provided Allen key and the provided screw (recommended variant for objectives with a small working distance).

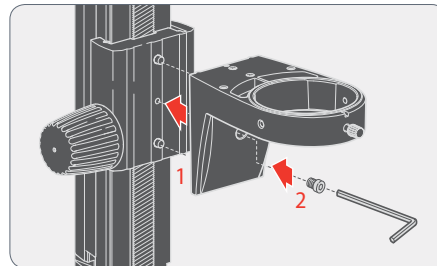

2. Alternatively, the microscope carrier can also be installed upside-down (recommended variant for objectives with a large working distance).

Assembling the Leica DMS300

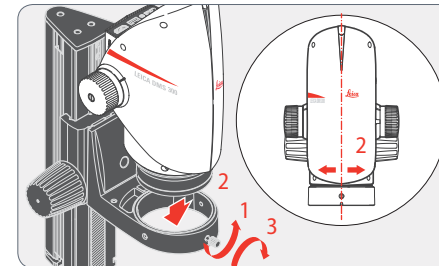

1. Unscrew the clamping screw.
2. Place the Leica DMS300 in the microscope carrier so that the notch in the microscope housing and the lower clamping screw overlap.
3. Fasten the microscope in place using the clamping screw.





10" monitor

Install on the column

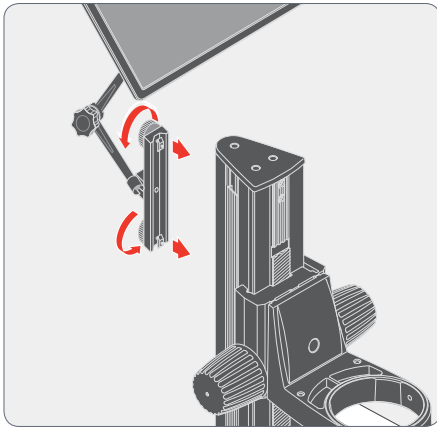

1. Align the mounting pins so that they are aligned with the vertical slot in the back of the focus column.
2. Insert the pins into the slot so that the mounting bracket is firmly seated on the focus column
3. Rotate the thumb screw so that the mounting pins rotate 90° clockwise.

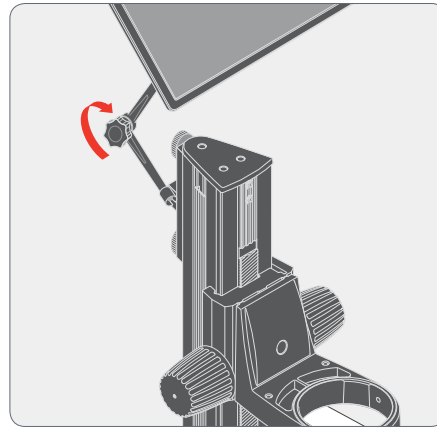

4. Slightly pull out on the thumb screw so that the mounting pins remain in place.
5. While pulling out on the thumb screw, rotate clockwise to lock the monitor mounting bracket in place.
6. The bracket can be positioned as desired on the back of the column.
7. Once the monitor bracket is secure, adjust the monitor using the knob on the mounting arm to move the monitor to the optimal working position.





Objective Installation

Instructions for safe assembly

 Hold the objective firmly during assembly and disassembly so that it does not fall onto the stage plate. Remove all specimens from the stage plate first.

 The objective is not part of the standard delivery of the Leica DMS300.

Assembly

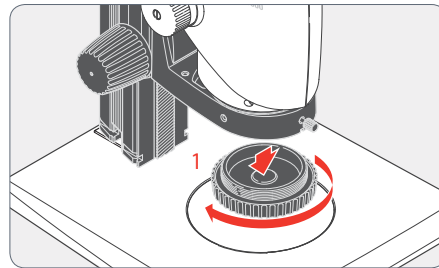

1. Remove the protective cap on the optics carrier by turning it.

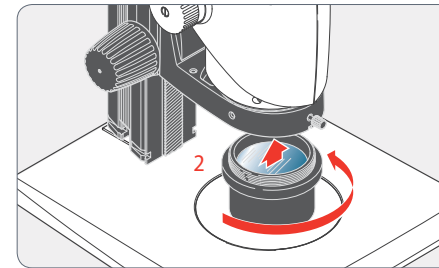

2. Screw the objective into the optics carrier.





Illumination: Installing the Leica LED3000 RL

Installing the Leica LED3000 RL

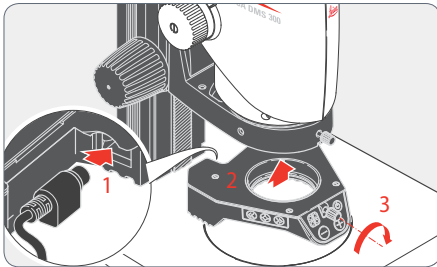

1. Connect the external power supply unit (10 450 266) to the Leica LED3000 RL.
2. Attach the Leica LED3000 RL to the objective from below.
3. Tighten the locking screw.

 The supported working distance is between 60 mm and 150 mm.

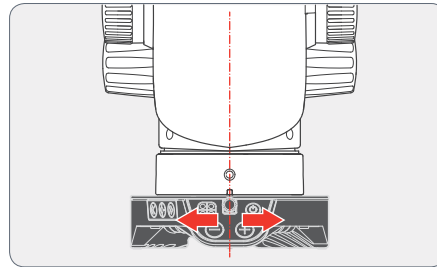

 Ensure that the locking screw of the illuminator and the locking screw of the optics carrier are on a straight line.

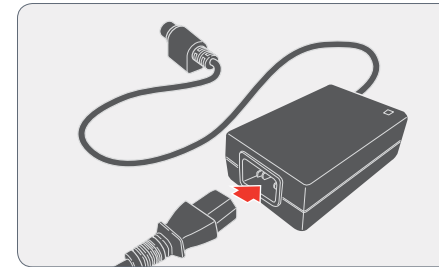

Connect the power supply to the power cable.





Illumination: Installing the Leica LED3000 RL (continued)

Installing optional accessories

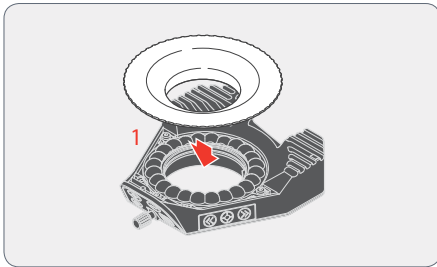

1. The optional diffuser is attached and screwed in below the ring illuminator.

 We recommend assembling the accessories on the Leica LED3000 RL on a table in reverse and then mounting them on the objective together.

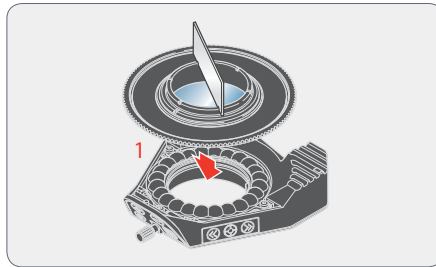

1. The optional polarization set (polarizer and analyzer) is attached and screwed in below the ring illuminator. The provided small metal plate is used as a fastening aid in the process.





Installation



HD Mode (Standalone)

Cables and Terminals, Activating HD Mode (Standalone)

General Instructions

 The Leica DMS300 is designed for the use of HD-capable (high definition) monitors. We highly recommend connecting the HD monitor using an HDMI connector and not using a DVI adapter, as otherwise proper function can no longer be guaranteed!

 Please only connect the provided 5 V power supply unit. Using an incorrect voltage can substantially damage the Leica DMS300.

Power supply and monitor

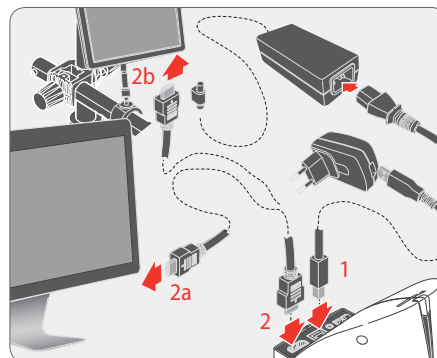

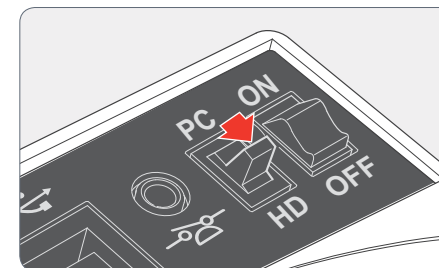

1. Connect the Leica DMS300 to a suitable power socket using the USB cable and power supply.
- 2a. Connect the Leica DMS300 to the HD monitor using the HDMI cable. Or:
- 2b. Connect the Leica DMS300 to the 10" monitor using the HDMI cable. Connect the 10" monitor to a suitable power socket.

Activating HD mode (standalone)



1. Set the mode switch to "HD" in order to set the Leica DMS300 to HD mode (standalone).

 An SD card with sufficient free memory must be inserted into the Leica DMS300 in order to save images in HD mode (standalone).

 In order to avoid instrument malfunctions, do not connect the Leica DMS300 to a computer while in HD mode (standalone).





PC Mode

Connecting a Computer, Installing Software, Activating PC Mode

Installation and connection

 For instructions on installing and using the software for PC mode, refer to the DVD provided with the Leica DMS300.

1. Place the DVD provided into the computer's disk drive and follow the instructions for installing the software.

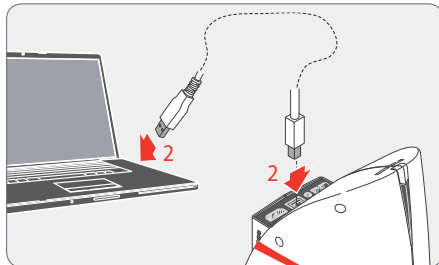

2. Connect the Leica DMS300 to the computer using the USB cable.

 The Leica DMS300 is powered by the computer via the USB cable. This changes the color of the status light. The status light is red when switching on the Leica DMS300; as soon as it is green, you can open the software and view, record or manage images.

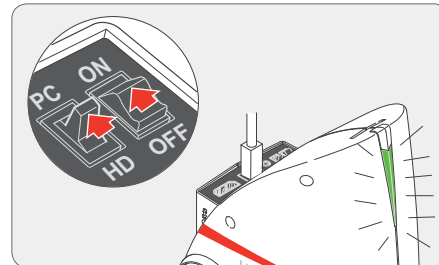

3. Follow the instructions in the software for adjusting and recording an image.

Activating PC mode

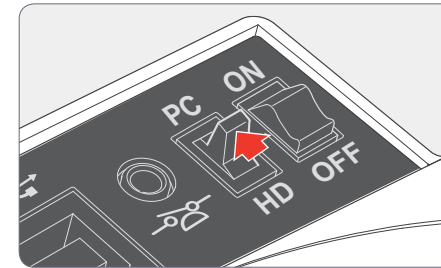

1. Set the mode switch to "PC" in order to set the Leica DMS300 to PC mode.

 Leica Application Suite has to be installed on the computer in order to use the Leica DMS300 in PC mode. The computer also has to have sufficient free hard drive space.





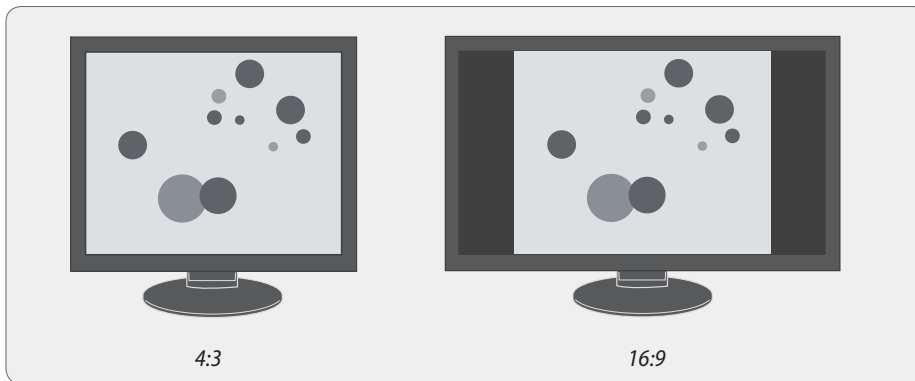

Limitations in PC Mode

Aspect ratio



 Images are always output in a 4:3 aspect ratio when the Leica DMS300 is connected to a computer – even if a 16:9 monitor is connected via HDMI. However, the image is displayed correctly on these kinds of devices, just with black on the screen edges.

Operation

 The Leica DMS300 is controlled entirely via the computer in PC mode. The front button, the remote control and the footswitch do not work. The menus for the camera are also not displayed on the HD monitor. Status information can be retrieved at any time despite this by using  on the remote control.

 Images cannot be saved onto the SD card in PC mode.





Startup procedure



Leica DMS300

Switching on the Leica DMS300

HD Mode (Standalone)

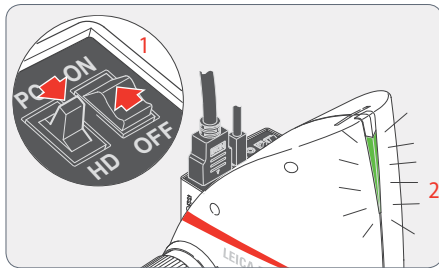

i Ensure that the objective is screwed onto the microscope, the mode switch is set to "HD" and the HD monitor is switched on.

1. Set the on/off switch to "ON" to switch on the Leica DMS300.
2. The status light's LED switches from red to green, a signal tone sounds and the live image is displayed on the HD monitor - the Leica DMS300 is ready to use.

i If the Leica DMS300 is connected to an HD monitor in PC mode:

- the remote control does not respond; in other words, the user menu does not appear.
- On the HD monitor, a live image is shown in 4:3 aspect ratio (with black bars right and left).
- The menu does not appear.
- The message "No camera" appears when starting the LAS-EZ software.

PC Mode

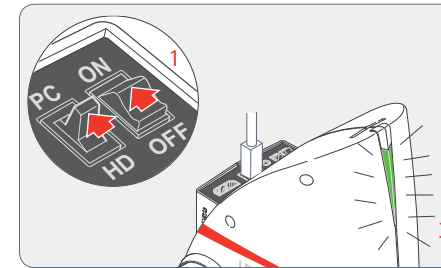

i Ensure that the objective is screwed onto the microscope, the mode switch is set to "PC" and the computer monitor is switched on.

1. Set the on/off switch to "ON" to switch on the Leica DMS300.
2. Start Leica Application Suite.
3. The status light's LED switches from red to green, a signal tone sounds and the live image is displayed on the computer – the Leica DMS300 is ready to use.







Switching on the Illumination

General Instructions

 The light from the Leica LED illuminator can be very bright. Avoid looking directly into the LEDs.

 The intensity of the illuminator can be adjusted in 10 increments.

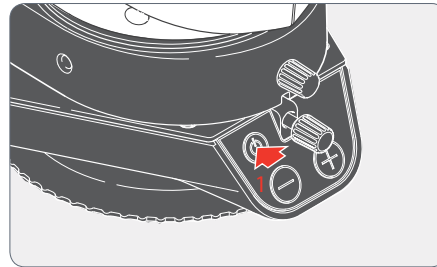

 When pressing the buttons, hold the keypad between your thumb and index finger. Avoid tapping the keypad with just one finger if possible.

Use

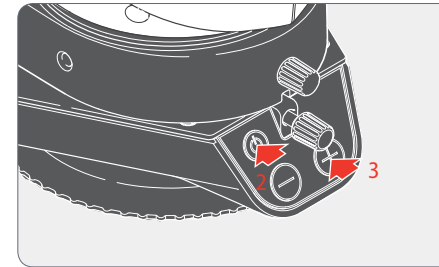

1. Switch on the illuminator by briefly pressing the  (ON/OFF) button. The green LED on the upper left corner now lights up.



2. Adjust the brightness by briefly pressing the  or  buttons.
3. Switch off the illuminator by briefly pressing the  button.





Focusing, Adjusting the Resistance of the Focus Drive

Focusing

Focusing raises or lowers the microscope using the focusing drive. The specimen detail is brought into sharp focus as soon as it is in the focal point of the objective.

- The focusing drive can be operated either left- or right-handed.

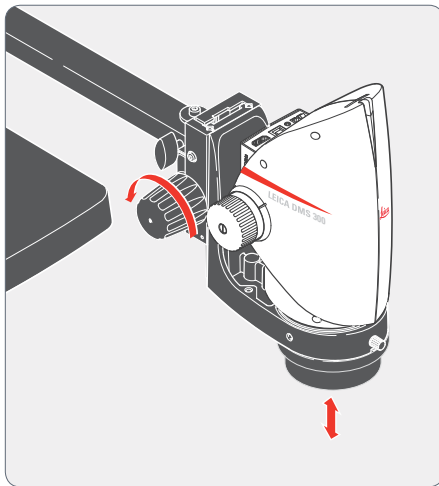

Boom Stand

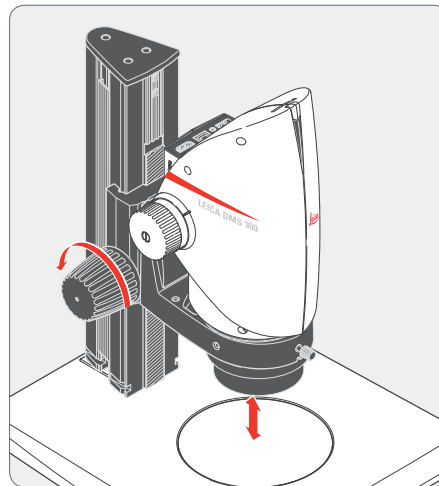

Incident light base

Adjusting the resistance

Is the focusing drive too loose or too tight? Does the equipment tend to slide downwards? The resistance can be adjusted individually depending on the equipment weight and personal preferences as follows:

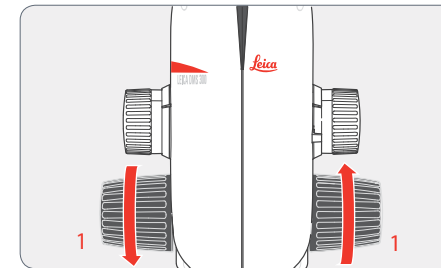

1. Grip the drive knobs with both hands and turn them towards each other until the desired resistance is reached during focusing.





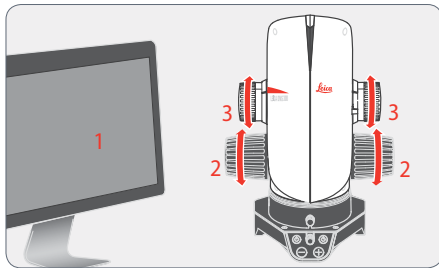

Changing Magnification, Click-stop Feature

Changing the magnification (zoom)



1. Look at the HD monitor.
2. Focus on the specimen.
3. Rotate the magnification changer until the desired magnification is configured or it has to be refocused.

 The rotary knob for the zoom can be used either left or right-handed.

 The magnification changer can optionally be operated either with or without click stops enabled. Continuous zoom is possible when the click stops are disabled, which many users find convenient. On the other hand, when the click stops are enabled, photographs, measurement results etc. can be reproduced more accurately.

 Parfocality: The Leica DMS300 is parfocally matched. If the specimen is in focus at the highest magnification level, this remains true across the entire magnification range.

Enabling and disabling click stops

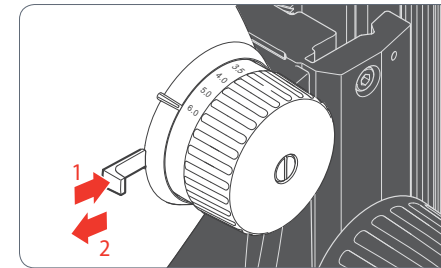

1. Push the button towards the knob to enable the click stops.
2. Push the button away from the knob to disable the click stops.





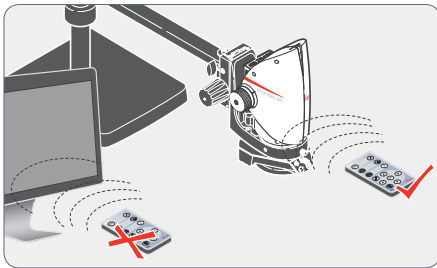

Remote control

General Instructions



Always keep the remote control for controlling the Leica DMS300 pointed towards the microscope's IR receiver.

 The remote control does not respond if the microscope is connected to a computer.

 Instead of the remote control, the front button or the footswitch (depending on the configuration) can be used to trigger the Leica DMS300.

Description

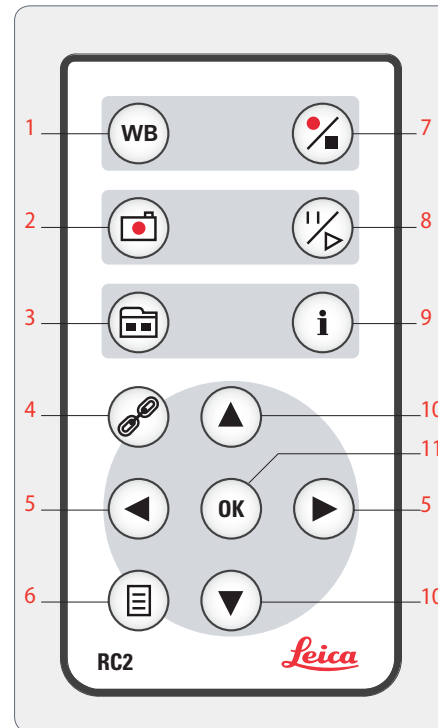

1. Perform automatic white balance
2. Save still image to SD card
3. Show/hide gallery, retrieve data from SD card
4. Pairing (microscope - remote control)
5. Left/right button, select illumination mode
6. Show/hide user menu
7. Start/stop video recording
8. Stop/continue live image
9. Show / hide information box
10. Up/down button, select overlay
11. OK / confirm





Remote Control (continued)

Checking the battery

1. Switch on the microscope and HD monitor so that you see the live image on the HD monitor.

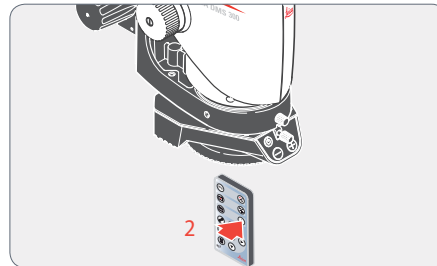

2. Hold the remote control in the beam path so that it faces upwards and press any key.

Because the microscope's chip also responds to the infrared range, you can see how the LED on top of the remote control lights up on the HD monitor. If this is not the case, the battery needs to be changed.

Changing the Battery

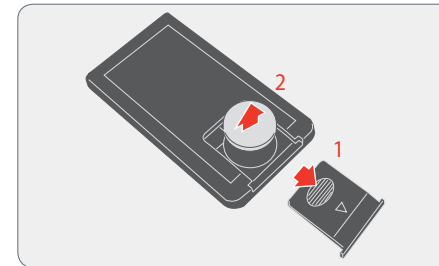

1. Remove the battery cover on the rear side of the remote control.
2. Replace the battery and close the battery cover.







"Pairing" the Leica DMS300 with a Remote Control

Pairing

 The Leica DMS300 and the remote control can be paired and then only respond to each other. This can be helpful when using multiple microscopes and remote controls.



1. Press the  button to start or end the process.

 In order to achieve successful pairing and avoid pairing by mistake, the 3rd step must be performed within four seconds.

 If a "timeout" is displayed after 4 seconds, press the "Pair" button again to start the process.

2. Select a button on the remote control that you want to define as the pair button. Only the  button cannot be used for this.
3. Press and hold your pair button until a corresponding confirmation is displayed on the HD monitor.
4. The microscope only responds to the remote control commands from this remote control.

Resetting to factory setting

1. Press the button  to start the process.
2. Press the button  until a corresponding confirmation is displayed on the HD monitor.

See more on this topic in our online videos at our website www.leica-microsystems.com.





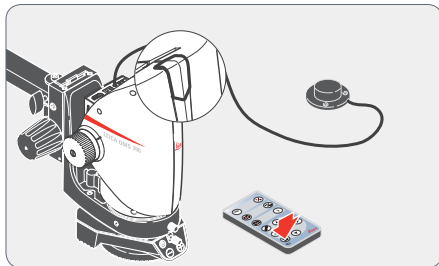

Configuring the Front Button or Footswitch

General Instructions



Both the Leica DMS300's front button and footswitch can be configured with the remote control as defined by the user.

 The default setting is "CAPTURE" for capturing an image.

 The Leica DMS300's front button and footswitch do not work in PC mode.

Configuring

1. Point the remote control towards the Leica DMS300.
2. Press the button  to show the user menu on the computer monitor.
3. Select "SETUP USER" in the main menu:





Configuring the Front Button or Footswitch (continued)

5. The following configurations are possible by selecting the corresponding option:
 - NONE: No Function
 - CAPTURE: Capture an image and save it to the SD card.
 - SHOW LAST: Show a preview of the most recently acquired image.
 - MOVIE: Start video recording or stop a video recording that is in progress. Saved to the SD card as an MP4 file.
 - OVERLAY: Show crosshair or overlay. Pressing this button multiple times scrolls through the list of crosshairs or overlays.
 - WHITE BAL: Run white balance for color correcting the camera. For additional information on white balance, refer to page 51.

See more on this topic in our online videos at our website www.leica-microsystems.com.



Operation







HD Mode (Standalone)

Checking Cables and Terminals

General Instructions

 The Leica DMS300 is designed for the use of HD-capable (high definition) monitors. We highly recommend connecting the HD monitor using an HDMI connector and not using a DVI adapter, as otherwise proper function can no longer be guaranteed!

 Please only connect the provided 5V power supply unit. Using an incorrect voltage can substantially damage the Leica DMS300.

Power supply and HD monitor

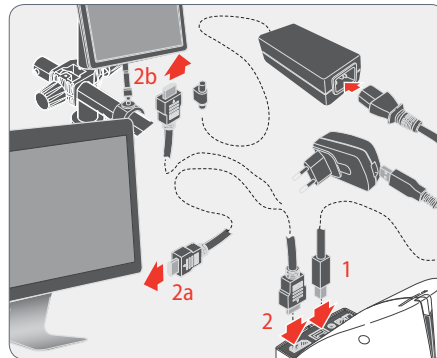

1. Check that the Leica DMS300 is properly supplied with power via the USB power supply.
- 2a. Check whether the Leica DMS300 is connected to the HD monitor properly via the HDMI cable. Or:
 - 2a. Check whether the Leica DMS300 is connected to the 10" monitor with the HDMI cable and the monitor is attached to a power socket.

HD Mode (Standalone)

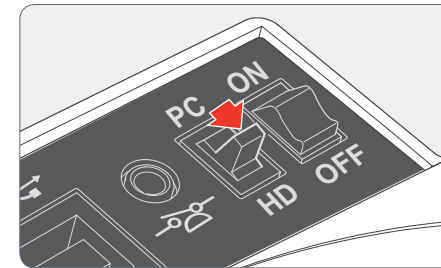

1. Check whether the mode switch is set to "HD" (standalone).

 An SD card with sufficient free memory must be inserted into the Leica DMS300 in order to be able to save images in HD mode (standalone).





Switching on the Leica DMS300

Switching on the Leica DMS300 (standalone)

 Ensure that the objective is screwed onto the microscope, the mode switch is set to "HD" and the HD monitor is switched on.

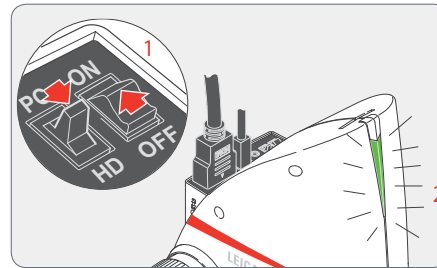

1. Set the on/off switch to "ON" to switch on the Leica DMS300.
2. The status light's LED switches from red to green, a signal tone sounds and the live image is displayed on the HD monitor – the Leica DMS300 is ready to use.





Information about SD Memory Cards

General Instructions

 Be absolutely certain to read the following instructions about formatting and handling the memory card provided in order to prevent malfunctions during image acquisition.

File system and formatting

The FAT file system has to be used so that the SD card works correctly and is detected by the Leica DMS300. Most memory cards are factory-formatted with FAT so that they can be used immediately.

An SD card cannot be formatted in the Leica DMS300. If it is necessary to format the card, use a computer to do so. You can also delete the files on the card in any digital camera that works with SD cards. During the deletion, the FAT file system is installed automatically.

Write protection

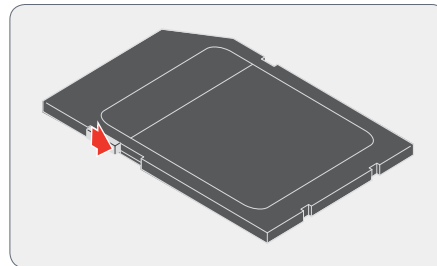

 Some SD memory cards are equipped with a slide for write protection. If the slide is pressed down, no new images can be saved. In addition, existing images are protected from being deleted.

If you cannot save any more images to the SD card, check to make certain that the write protection is disabled.

Orientation

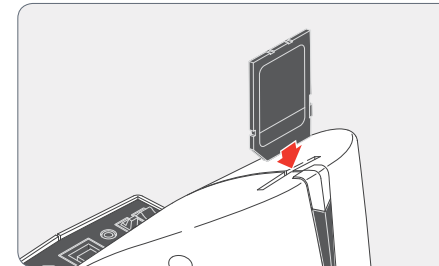

 Make sure that the memory card is oriented correctly before inserting it into the Leica DMS300. Accidentally inserting the card the wrong way around could damage the microscope.

Capacity

Class 4 and 6 SD cards can be used with the Leica DMS300. SDHC (high capacity) cards up to 32 GB are also supported.



Capturing Images without a Computer

General Instructions

 Before capturing the image, ensure that enough memory is available on the SD card and that write protection has not been activated. If the SD memory card is full or protected, the Leica DMS300's status light stays red, and you cannot acquire any more images.

 In order to avoid instrument malfunctions, do not connect the Leica DMS300 to a computer while in HD mode (standalone).

 In the highest resolution, a single image takes up approx. 1.3 megabytes of storage space on the SD card. This means that per gigabyte of capacity, you can save over 700 images.

Recording

1. Focus on the specimen.

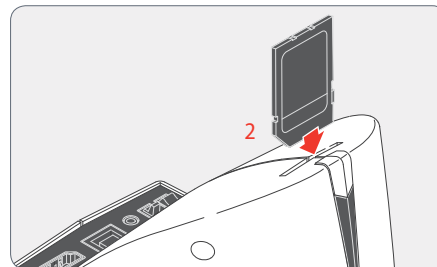

2. Push the SD memory card into the slot on top of the Leica DMS300 until it clicks into place.

The Leica DMS300's status light is illuminated in green. The microscope is now ready to save images to the SD memory card.

 Depending on the configuration, the front button can be used for capturing an image. For additional information, refer to page 43.

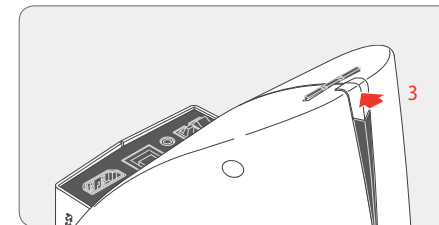

3. Briefly press the Leica DMS300's front button to capture an image.

You hear a signal tone as confirmation. While the image is being acquired, the status light flashes green and the word "Capture..." flashes on the HD monitor.

4. In order to remove the SD card from the camera, press on the SD memory card in the memory slot so that it pops out.

You can now transfer the images to your computer using an SD memory card reader.

















Displaying Images and Videos without a Computer

 The Leica DMS300 can display images and video clips directly on an HD monitor.

Control via remote control:

1.  : Show/hide miniature view.
2.   : Select miniature image (JPG or MP4).
3. For a JPG image:
 -  : Display image in full size and zoomed in 1x, 2x, 3x (when pressing repeatedly).
 -   : Next/previous image.
3. For an MP4 video clip:
 -  : Play video.
 -  : Stop/play video.
 -   : Rewind/fast forward video.
4. In order to return to the live image, press the , , or  button – if you are in a zoomed-in image, you may need to do this more than once.

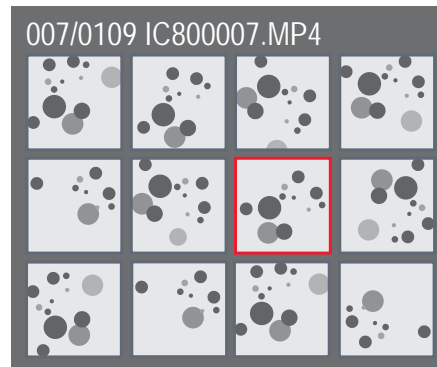

Thumbnail view





Reproduction / full screen



White Balance

General Instructions

 The white balance ensures that the specimen is shown in neutral colors. We recommend carrying out a new white balance adjustment whenever you change the illumination type or color temperature. This is particularly necessary if you are working with halogen light that can be switched from yellow (low intensity) to blue (high intensity).

 Configure the white balance via the user menu using the remote control. Depending on the configuration, automatic white balance can also be carried out using the front button or the footswitch.

 The white balance of the microscope is factory set to automatically provide optimum results when used in conjunction with a Leica LED illuminator.

Manual white balance

- Manual white balance is described on [page 58](#).

Automatic white balance

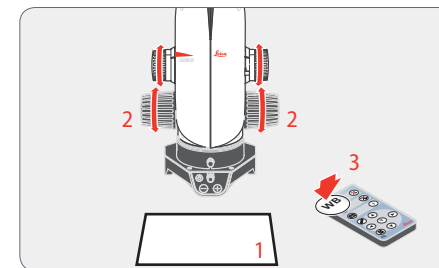

1. Position a gray chart or a gray, neutral object under the microscope so that the entire image field is filled in.
2. Adjust the illumination as desired.
3. Press the  button on the remote control or – if configured accordingly – press and hold the front button or footswitch for 5 seconds. The microscope now carries out an automatic white balance adjustment.







PC Mode

Checking Cables, Terminals and Software

Software

 Leica Application Suite EZ has to be installed on the computer in order to use the Leica DMS300 in PC mode. The computer also has to have sufficient free hard drive space.

 If you want to perform demanding image analyses, the Leica Application Suite (LAS Core) and countless (optionally available) LAS modules are available.

Leica DMS300 and computer connection

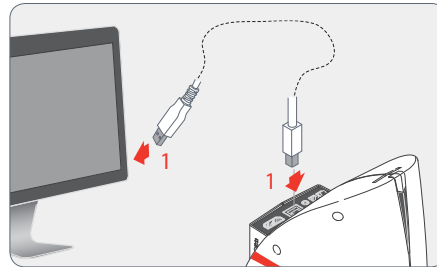

1. Check whether the Leica DMS300 and the computer have been connected properly via the USB cable provided.

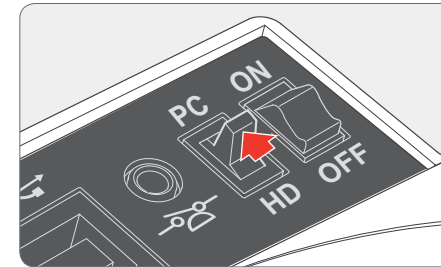

 The Leica DMS300 is powered by the computer over the USB cable.

PC Mode



1. Check whether the mode switch is set to "PC".

 For possible limitations in PC mode, refer to page 34.

 The Leica DMS300 is controlled entirely via the computer in PC mode. The front button, the remote control and the footswitch do not work. Status information can be retrieved at any time despite this by using  on the remote control.





Switching on the Leica DMS300

Switching on the Leica DMS300 (PC mode)

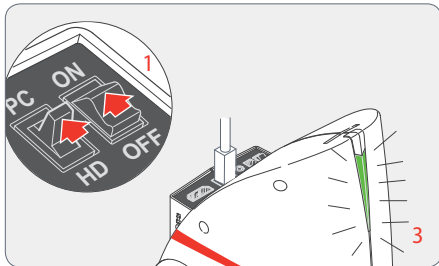

1. Set the on/off switch to "ON" to switch on the Leica DMS300.
2. Start Leica Application Suite EZ.
- 3 The status light's LED switches from red to green, a signal tone sounds and the live image is displayed on the computer – the Leica DMS300 is ready to use.
4. Follow the instructions in the software for adjusting and acquiring an image.



For additional information on Leica Application Suite, please refer to "LAS Help".

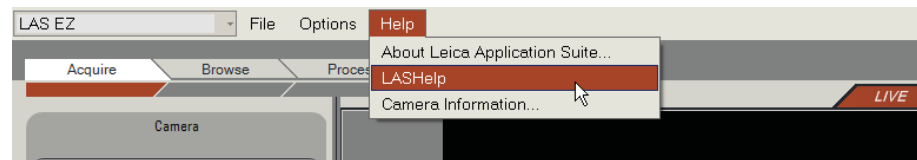



Additional Use of a HD Monitor in PC Mode

General Instructions

 In PC mode, the microscope image is always shown in the preview window of Leica Application Suite. In addition, another HD monitor can be connected via the HDMI interface.

 The resolution on the connected HD monitor is limited by the live image resolution of the LAS EZ software. Due to technical limitations, it is not possible to display a Full HD live image on the connected HD monitor. In order to do this, you have to switch the Leica DMS300 to HD mode (standalone) (see page 46).

Connecting the HD monitor

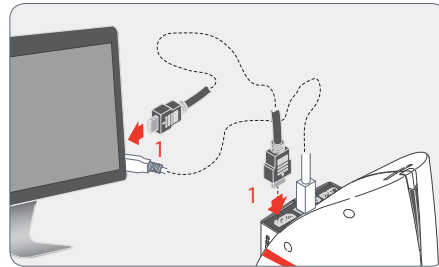

1. Connect the Leica DMS300 to the HD monitor using the HDMI cable.







User Menu



Calling up the User Menu





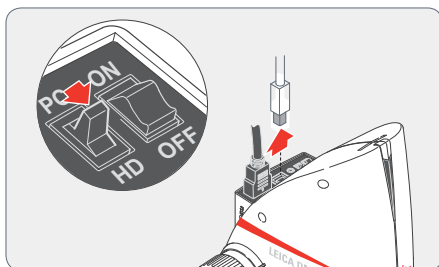

General Instructions

 The Leica DMS300 is controlled entirely via the computer in PC mode. The front button, the remote control and the footswitch do not work. The menus for the camera are also not displayed on the HD monitor. Status information can be retrieved at any time despite this by using  on the remote control.



Check to ensure that the Leica DMS300 is in HD mode and that a live image is shown on a connected HD monitor.

Calling up and closing the user menu

1. Point the remote control towards the Leica DMS300.
2. Press the  button to show the user menu on the HD monitor.
3. Press the   /   buttons to select a menu item.
4. Press the  button to confirm a menu item.
5. Press the  button again to hide the user menu.





See more on this topic in our online videos at our website www.leica-microsystems.com.



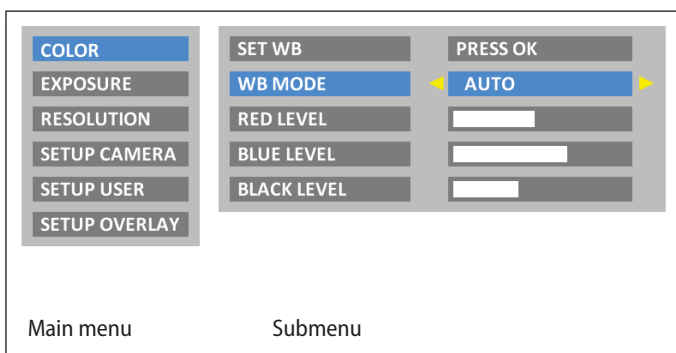

Automatic White Balance





Activating automatic white balance

1. Press the  button on the remote control.
2. Call up the "COLOR" entry.
3. Set the value for "WB MODE" to "AUTO".
4. Press the  button to leave the menu.

 The values for "RED LEVEL", "BLUE LEVEL" and "BLACK LEVEL" cannot be adjusted if the "WB MODE" setting is set to "AUTO".

 The "COLOR" function makes it possible to adapt the camera chip to the ambient light so that color-neutral images can be acquired.

 Whenever possible, always use a neutral gray chart or another color-neutral object to attain optimum results.

 For transmitted light specimens, configuring the white balance to the pure transmitted light at moderate brightness is recommended (without the specimen).

See more on this topic in our online videos at our website www.leica-microsystems.com.



MANUAL WHITE BALANCE

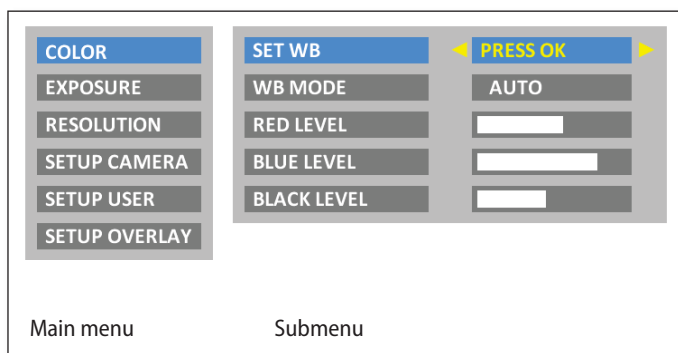



 The "COLOR" function makes it possible to adapt the camera chip to the ambient light so that color-neutral images can be acquired.

 Whenever possible, always use a neutral gray chart to attain optimum results.

Adjusting the white balance manually (recommended)

1. Place the gray chart under the microscope so that the entire field of view is filled in.
2. Press the button  on the remote control. The white balance is calibrated and saved to the camera.

Alternatively, you can also calibrate the white balance using the user menu.

1. Press the button  on the remote control.
2. Call up the "COLOR" entry.
3. Select the "SET WB" menu item.
4. Press the button .

 If you do not have a neutral gray area in the image or if the illumination has a very strong color cast, you can manually set the values for "RED LEVEL", "BLUE LEVEL" and "BLACK LEVEL" until the image displays a harmonious gray.

 The white balance mode is always set to "MANUAL" after manually adjusting the white balance, even if it was set to "AUTO" previously.

See more on this topic in our online videos at our website www.leica-microsystems.com.



Exposure

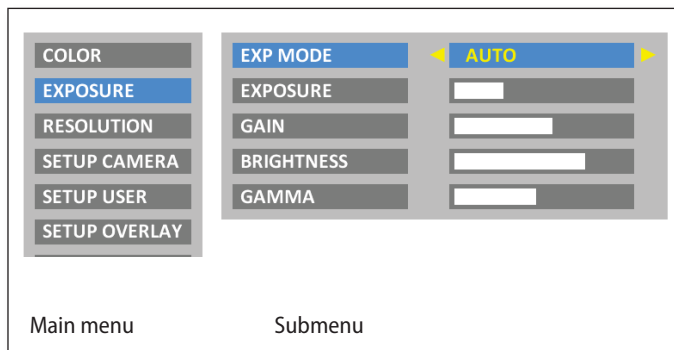
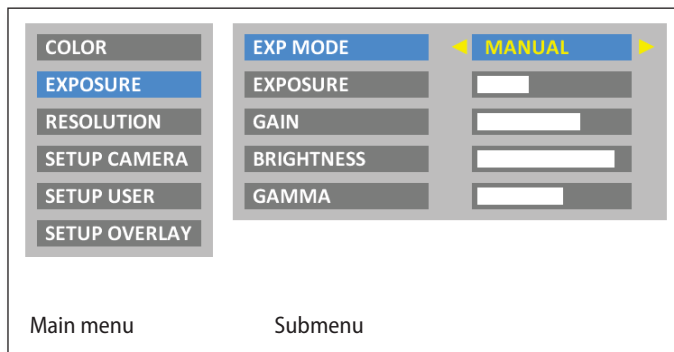

Manual exposure

1. Press the button  on the remote control.
2. Call up the "EXPOSURE" entry.
3. Set the value for "EXP MODE" to "MANUAL" for manual exposure.
4. Correct the values for "EXPOSURE", "GAIN" and "GAMMA" until you obtain the desired results for the image.

Automatic exposure

1. Press the button  on the remote control.
2. Call up the "EXPOSURE" entry.
3. Set the value for "EXP MODE" to "AUTO" for automatic exposure.
4. Correct the values for "BRIGHTNESS" and "GAMMA" until you obtain the desired results for the image.

See more on this topic in our online videos at our website www.leica-microsystems.com.



Resolution

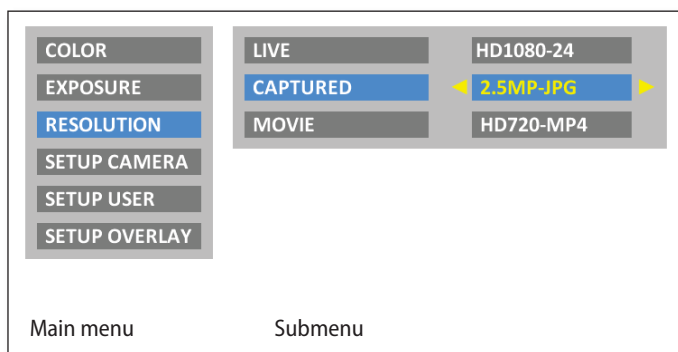

 The "RESOLUTION" menu lets you define the resolution individually for the live image on the computer, capturing individual images and capturing video. This provides optimum results in every situation.

Resolution of the live image (LIVE)

Defines the resolution of the live image. The following resolutions are available:

- HD720-50 and HD720-60: 1280×720 pixels, at 50 Hz or 60 Hz image refresh rate.
- HD1080-24 and HD1080-30: 1920×1080 pixels, at 24 Hz or 30 Hz image refresh rate, progressive.
- HD1080-50 and HD1080-60: 1920×1080 pixels, at 50 Hz or 60 Hz image refresh rate, interlaced.

Select a resolution that can be displayed on the HD monitor correctly without flickering and without an error message.





Resolution (continued)

If a resolution cannot be displayed and the HD monitor remains black, you can do the following to display a live image again in the HD monitor:



Use the tip of a ball-point pen (or a bent paperclip) to press the hidden reset button:

- Pressing the reset button for the first time displays the current live image resolution on the HD monitor.
- Pressing it a second time switches to the next live image resolution, and a signal tone is output.
- Repeat the last step until a live image is displayed. The camera can activate 6 different resolutions in sequence.



A double signal tone is output when activating the recommended default resolution of HD1080-50.

Resolution of the captured image (CAPTURED)

Defines the resolution of the captured image saved directly to the SD card. The following resolutions are available:

- 1.1 MP - JPG: 1216×912 pixels
- 2.5 MP - JPG: 1824×1368 pixels

Resolution of videos (MOVIE)

Defines the resolution of video captures saved directly to the SD card. The following resolutions are available:

- HD720-MP4: 1280×720 pixels
- HD1080-MP4: 1920×1080 pixels

About 50 MB of data are produced per minute with HD720 and 100 MB with HD1080 (slightly dependent on the contents and compression applied). A new file is created each time a file size of 1 GB is reached; capturing continues without interruption. Video capturing is discontinued if the SD card runs out of memory.

See more on this topic in our online videos at our website www.leica-microsystems.com.



Camera Settings

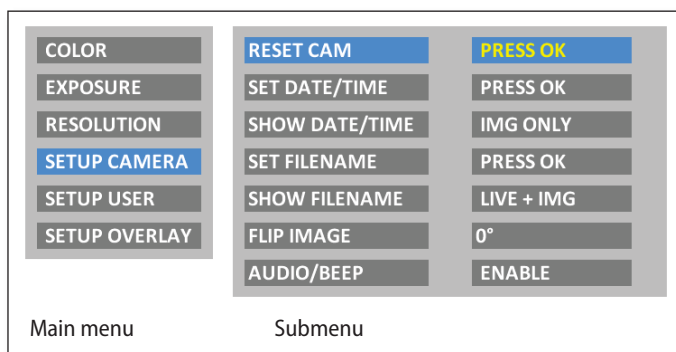

 The "SETUP CAMERA" menu lets you configure various internal parameters, such as the date and time, the file name for images on the SD card or whether a signal tone should sound each time an image is captured.

Reset camera (RESET CAM)

Resets the microscope to the factory default settings. All user information (such as white balance, resolution, etc.) is reset. Select this function if you are getting the impression the microscope is not responding normally or a setting has not been made correctly.

 Alternative method for resetting the camera: Use the tip of a ball-point pen (or a bent paperclip) to press hidden reset button: Hold the reset button down for at least 5 seconds until a signal tone sounds.

Set the date and time (SET DATE/TIME)

This command sets the date and time as well as the format for displaying them. The following formatting options are available for selection: YYYY.MM.DD – DD.MM.YYYY – MM/DD/YYYY

Display the date and time (SHOW DATE/TIME)

Depending on the setting, this does not display the date and time at all, just displays it in the live image, just in image captures or in both the live image and image captures. The date and time are displayed or written into the top right corner of the image.

Set the filename (SET FILENAME)

Lets you freely select the first four characters of the filename for both single exposures and video recordings. These characters are followed by sequential numbering, followed by either JPG for individual images or MP4 for video recordings.





Camera Settings (continued)

Display the filename (SHOW FILENAME)

Depending on the setting, this does not display the filename at all, just displays it in the live image, just in image captures or in both the live image and image captures. The filename is also shown or written into the top right corner of the image.



If you save the file name or the date and time into images, they cannot be deleted later, even if you rename the files or change the date.

Rotate image (FLIP IMAGE)

Rotates the image by 180°.

Signal tone (AUDIO/BEEP)

Depending on the setting, you can have a brief signal tone sound after capturing an image. This can be helpful when working with a footswitch if you want to capture images without taking your eyes off the microscope.

See more on this topic in our online videos at our website www.leica-microsystems.com.



User-Defined Settings

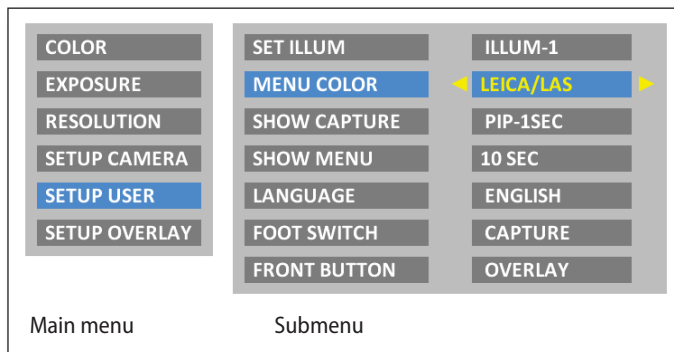

 The "SETUP USER" menu lets you change or switch certain user-specific settings to make working with the microscope a more enjoyable experience.

Set the illumination mode (SET ILLUM)

These settings allow you to define up to three different illumination modes, such as one for transmitted light or one for polarized light. This can save the current camera settings for recurring acquisition situations and retrieval again at any time.

Press ◀ ▶ to select illumination mode 1, 2 or 3. Press  to save the current camera settings under the displayed illumination mode.

 In order to select a pre-defined or newly defined illumination mode quickly without calling up the user menu, press in the live image ◀ ▶.

Set menu color (MENU COLOR)

Currently, two color schemes are available for the menu guidance. Additional colors may be provided in the future via a firmware update.





User-Defined Settings (continued)

Show the capture (SHOW CAPTURE)

Lets you set whether or not a recently saved image is to be displayed in full screen or as picture-in-picture (PIP) on the monitor after capturing an image. You can also select whether the created capture is to be displayed for one second, three seconds or permanently (INFINITE).

Display the menu (SHOW MENU)

Defines how long the menu is displayed on the screen. You can stop the menu from being displayed at any time by pressing the menu button again or selecting a menu entry.

Set the language (LANGUAGE)

Lets you set the language for menu guidance. Select the fifth entry in the main menu if you have (unintentionally) selected an Asian language that uses logograms and want to return to a menu display that is alphanumeric. The menu entry for selecting the language is always added in English as well.

Configure the footswitch (FOOT SWITCH)

Lets the footswitch be configured with another function. By default, pressing the footswitch triggers image acquisition. However, you can choose if this should perform a white balance adjustment, record a video or display the last capture instead.

Configure the front button (FRONT BUTTON)

Lets you configure another function for the front button. By default, pressing the front button triggers image acquisition. However, you can choose if this should perform a white balance adjustment, record a video or display the last capture instead.

See more on this topic in our online videos at our website www.leica-microsystems.com.







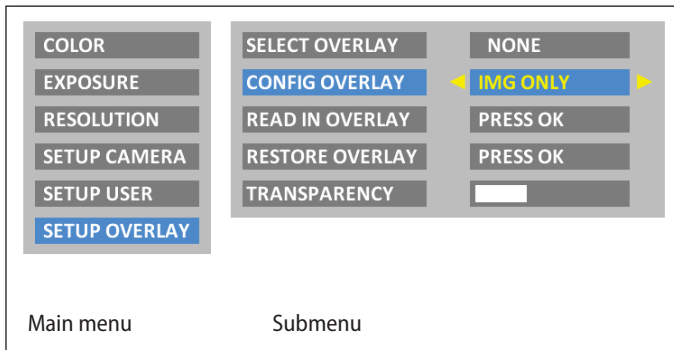



Setting the overlay (SETUP OVERLAY)



 The Leica DMS300 lets you superimpose predefined or user-specific images in the live image and in captured images. These superimposed images (called overlays) can contain anything, but usually just contain a few elements such as a crosshair or company logo. Up to 10 overlays can be defined, of which the first overlay (01) is reserved for displaying a small histogram in the bottom left corner. Overlays 02 through 10 can contain either predefined or user-specific content and let you configure your microscope for special tasks.

Select an overlay (SELECT OVERLAY)

Press   to select another overlay. Press  to activate the selected overlay and leave the menu.

 If you want to quickly display other overlays, press  when the live image is displayed   to show the next or previous respective overlay.

Configure an overlay (CONFIG OVERLAY)

Depending on the setting, this does not show an overlay, only shows the overlay in the live image or shows it in both the live image and the image capture.

Import an overlay (READ IN OVERLAY)

Imports user-specific overlays from the SD card from the "Overlay" directory. The overlays need have both the appropriate resolution and a specifically defined filename. Various overlays are available for download on the Leica Microsystems website, as well as a manual for how to create your own overlays. Follow those instructions to create new overlays.





Setting the Overlay (continued)

Restore an overlay (RESTORE OVERLAY)

Resets the overlays to the factory setting: A histogram, a Leica logo, a crosshair over the entire live image and a small crosshair in the middle of the live image.

Set transparency (TRANSPARENCY)

The overlay's edges are more or less prominent depending on the selected setting.



This setting does not change the transparency of the overlay.

See more on this topic in our online videos at our website www.leica-microsystems.com.











Configuring Predefined Illumination Scenarios

Changing the illumination mode

 The Leica DMS300 is supplied with various illumination modes that cover a wide spectrum of possible situations.

1. Press   on the remote control to display the current illumination mode on the HD monitor.
2. Press   again to switch to the next illumination mode. The microscope immediately switches the illumination mode and sets the stored parameters.
3. Wait until the displayed illumination mode disappears from the monitor. This means that illumination mode is now active.

 To return to the last selected mode, press   until the "LAST USED" setting appears.

 If you do not press   for 5 seconds, the selected illumination mode is applied.

Sequence



Service





Care, Maintenance, Contact Persons

General

We hope you enjoy using your high-performance microscope. Leica microscopes are renowned for their robustness and long service life. Observing the following care and cleaning tips will ensure that even after years and decades, your Leica microscope will continue to work as well as it did on the very first day.

Warranty benefits

The guarantee covers all faults in materials and manufacture. It does not, however, cover damage resulting from careless or improper handling.

Contact address

If your instrument no longer works perfectly, contact your Leica Microsystems representative. You can find information on worldwide Leica representatives on the Leica Microsystems website: www.leica-microsystems.com.





Care, Maintenance, Contact Persons (continued)

Care

- Keeping all optical components clean is important for maintaining good optical performance.
- If any optical surface becomes badly coated with dust or dirt, flush the surface using a syringe or by brushing it off with a camel hair brush before attempting to wipe it clean.
- Optical surfaces should be cleaned using a lint-free cloth, lens cloth or cotton swab soaked in ethanol or a commercially available glass cleaner. Do not use alcohol.
- Avoid excessive use of solvents. The lint-free cloth, lens cloth or cotton swab should be soaked with solvent, but not so wet that solvent runs over the lens.
- Protect your microscope from moisture, fumes and acids and from alkaline, caustic and corrosive materials. and keep chemicals away from the instruments.
- Plugs, optical systems and mechanical parts must not be disassembled or replaced, unless doing so is specifically permitted and described in this manual.
- Protect your microscope from oil and grease.
- Do not grease guide surfaces or mechanical parts.

Protection from dirt

Dust and dirt will affect the quality of your results.

- Put an optionally available dust cover over the microscope when it will not be used for a long time.
- Keep accessories in a dust-free place when not in use.





Care, Maintenance, Contact Persons (continued)

Cleaning polymer components

Some components are made of polymer or are polymer-coated. They are, therefore, pleasant and convenient to handle. The use of unsuitable cleaning agents and techniques can damage polymers.

Permitted measures

- Clean the microscope (or parts of it) using warm soapy water, then wipe using distilled water.
- For stubborn dirt, you can also use ethanol (industrial alcohol). When doing so, follow the corresponding safety regulations.
- Remove dust with a pneumatic rubber bulb or with a soft brush.
- Clean the objectives with special optics cleaning cloths and pure alcohol.

Servicing

- Repairs may only be carried out by Leica Microsystems-trained service technicians. Only original Leica Microsystems spare parts may be used.

Danger of electric shock



Risk of electric shock. Removing the cover of the Leica DMS300 exposes electrically live parts, which, if touched, can cause potentially fatal injuries. Have technical service carried out by a Leica Microsystems authorized dealer.





Spare parts

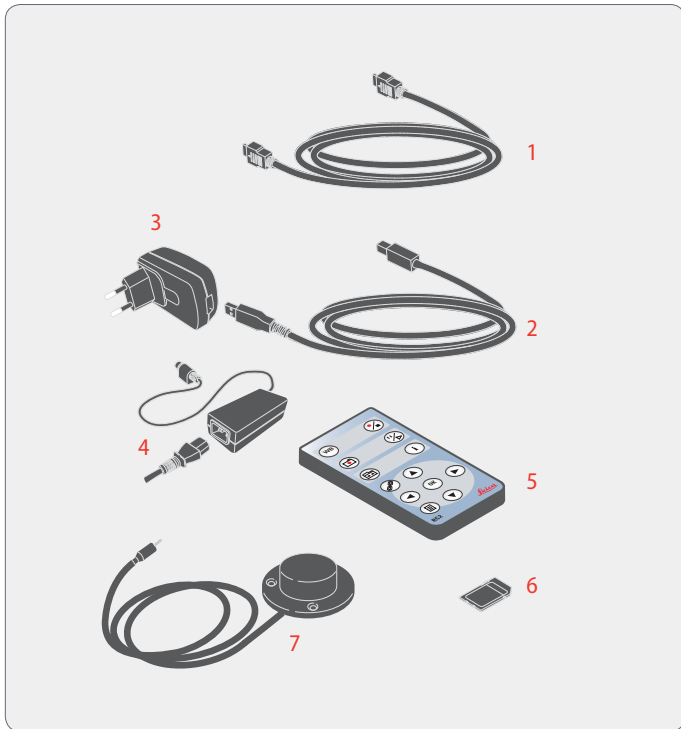

Item	Leica article number	Designation
1	19 004 872	HDMI cable (2 m)
2	19 004 871	USB cable (1.8 m)
3	13 302 708 946 915	5 W USB adapter with interchangeable connector
4	19 003 658	25 W power supply for Leica ring light illuminator
5	19 004 873	RC2 remote control
6	19 004 870	SD card (4 GB)
7	12 730 229	Footswitch





Specifications





Technical Data

Live image (Full HD): Objective

Optical data	Leica DMS1000
Max. resolution	142 lp/mm
Max. FoVx	32 mm
Max. FoVy	18 mm
Max. DoF	3.5 mm
Working distance	114 mm
Max@22"-monitor	15 x – 119 x

Live image (Full HD): Achromatic objective

Optical data	Leica DMS300@ highest zoom position	Leica DMS300@ lowest zoom position
Resolution	142 p/mm	24 lp/mm
FoVx	4.06 mm	32.44 mm
FoVy	2.28 mm	18.25 mm
DoF	0.178 mm	3.448 mm
Max@22"-monitor	119.3 x	15.1 x

Objective

Optics carrier	
Design engineering	Multi-layered tempered optics system with beam path and main objective, lead-free
Coding	Fully coded zoom
Specific surface resistivity (housing)	2×10 ¹¹ Ω/mm ² Discharge time <2 seconds from 1000V to 100V
Engageable zoom notches	Eight switchable positions, for repetitive tasks
Standard objective	Achromatic objective 0.8x

* With 10" monitor





Technical Data (continued)

Leica DMS300 - digital camera

Optics carrier	
Live image resolution	HD ready: 1280×720 - 50 Hz/60 Hz - 30 fps Full HD: 1920×1080 - 50 Hz/60 Hz/25 Hz/30 Hz - 30 fps PC: 1600×1200 - 10 fps / 1024×768 - 24 fps
Image resolution (capture)	2.5 megapixels (1824×1368) 1.1 megapixels (1216×912)
Video resolution	HD1080 (1090×1920) HD720 (1280×720)
Pixel size	3.34 μm × 3.34 μm
Sensor grade	Aptina 1/2.3" CMOS
Sensor size	6.1 mm × 4.6 mm
Exposure time	0.5 msec - 500 msec
Gain	1× to 12×
Color depth	3×8 bit = 24 bit
File formats	Image: JPEG Video: MP4

Accessories	
Supported operating systems	Windows XP, Windows 7, Mac OS X
Leica Software	PC: Leica LAS & LAS EZ software Mac: Leica Acquire Software
Computer system (recommended)	PC or Mac, Intel Core 2 Duo, >2.4 GHz, 4 GB RAM, 24-bit graphics, 1248 × 1024



Technical Data (continued)

Electronic interfaces

Accessories	
Computer	USB 2.0, standard USB plug type B
High-definition connector	HDMI 1.3, standard HDMI connector type A
On/Off switch	Available
PC/HD switch	Available
Reset button	Display for the current resolution, change to next resolution, reset, firmware upload
Remote control	RC2 infrared remote control, with button battery type CR2025
Remote trigger (optional: 12730229)	Hand and foot trigger, with 1.5 m cable
SD card (Secure Digital)	SD HC compatible, 128 MB – 32 GB
Status LED	3 colors: green – power on, yellow – busy, red – error
Power supply	Via USB cable to computer or to external 5 V USB power supply unit
Power requirement	5 W

Miscellaneous

Operating temperature range	+10 °C to 40 °C
Rel. humidity	10 - 90 %
Weight	1.3 kg
CE Declaration of Conformity	Available
Tested standards	EMI/RFI: EN 55011 EN 61010-1 EMC: EN 61326-1





Optical data

Objective	Achr. 0.8×	
Working distance	114 mm	
Field of view (zoom setting)	FOVx	FOVy
0.75	32.46	18.26
1.0	24.36	13.70
1.25	19.48	10.96
1.6	15.22	8.56
2.0	12.18	6.85
2.5	9.74	5.48
3.2	7.61	4.28
4.0	6.09	3.42
5.0	4.87	2.74
6.0	4.06	2.28

Objective		Achr. 0.8×	
Monitor	Zoom setting	Total mag.	DOF
10"	0.75	6.8	5.45
	1.0	9.1	2.10
	1.25	11.4	1.45
	1.6	14.5	0.97
	2.0	18.2	0.69
	2.5	22.7	0.50
	3.2	29.1	0.36
	4.0	36.3	0.28
	5.0	45.4	0.22
	6.0	54.5	0.18
19"	0.75	13.0	5.45
	1.0	17.3	2.10
	1.25	21.6	1.45
	1.6	27.6	0.97
	2.0	34.5	0.69
	2.5	43.2	0.50
	3.2	55.3	0.36
	4.0	69.1	0.28
	5.0	86.4	0.22
	6.0	103.6	0.18

Objective		Achr. 0.8×	
Monitor	Zoom setting	Total mag.	DOF
22"	0.75	15.0	5.45
	1.0	20.0	2.10
	1.25	25.0	1.45
	1.6	32.0	0.97
	2.0	40.0	0.69
	2.5	50.0	0.50
	3.2	64.0	0.36
	4.0	79.9	0.28
	5.0	99.9	0.22
	6.0	119.9	0.18
24"	0.75	16.4	5.45
	1.0	21.8	2.10
	1.25	27.3	1.45
	1.6	34.9	0.97
	2.0	43.6	0.69
	2.5	54.5	0.50
	3.2	69.8	0.36
	4.0	87.2	0.28
	5.0	109.0	0.22
	6.0	130.8	0.18



Dimensional Drawings

Leica DMS300

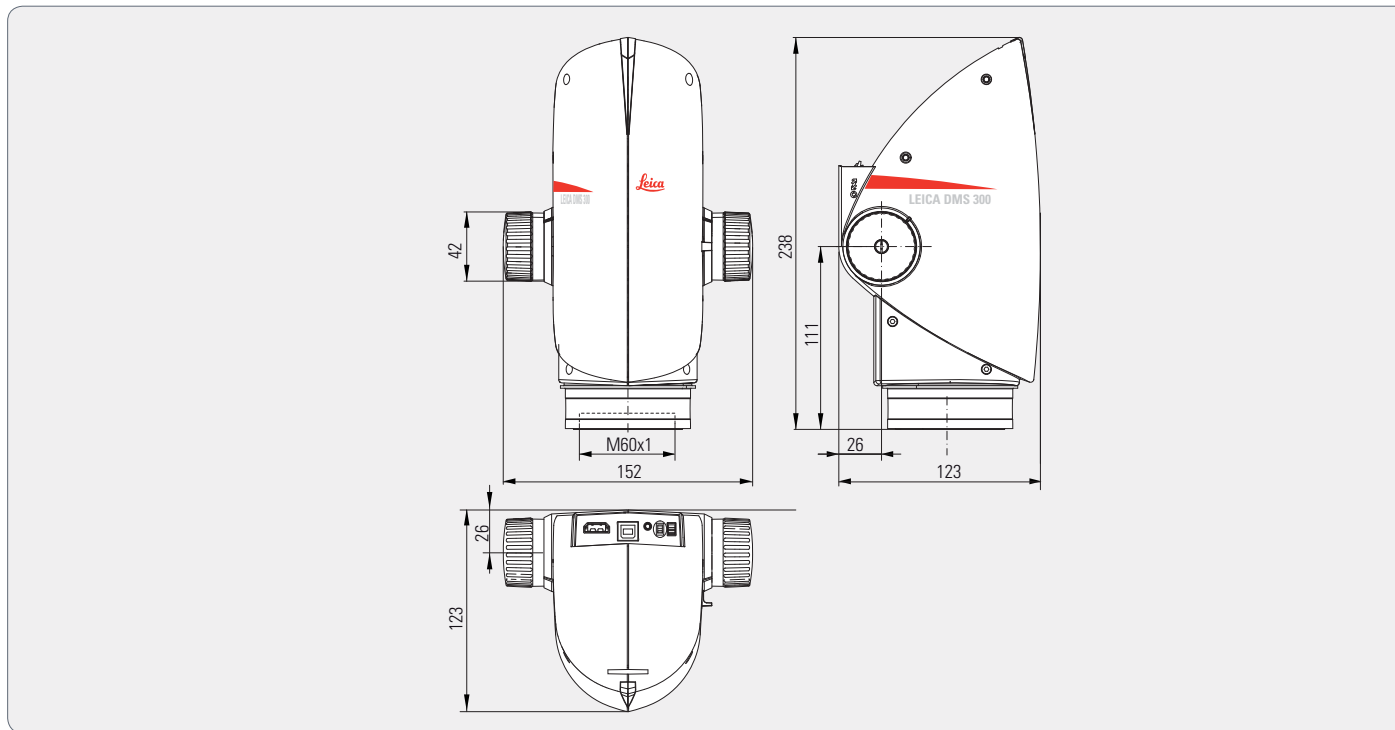



Leica DMS300 with Incident Light Stand

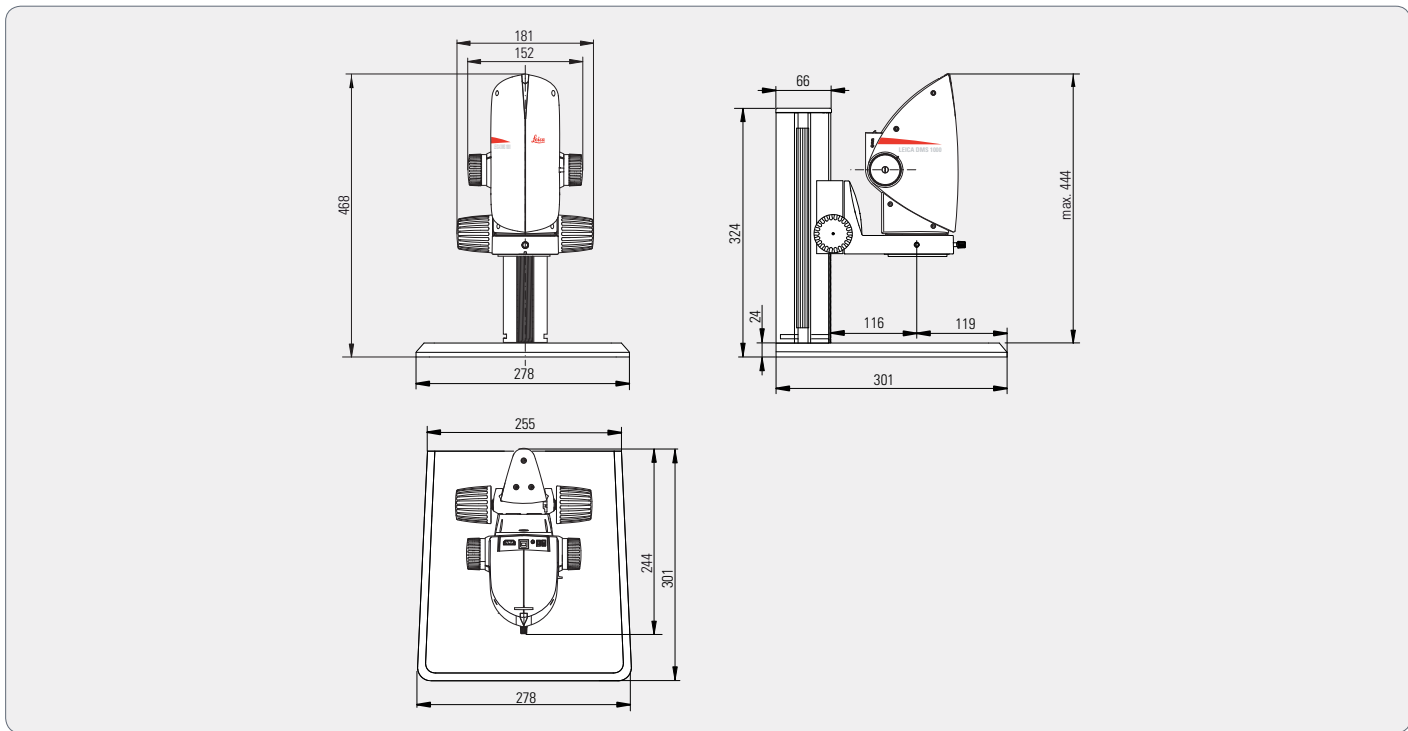



Leica DMS300 with Swing-arm Stand

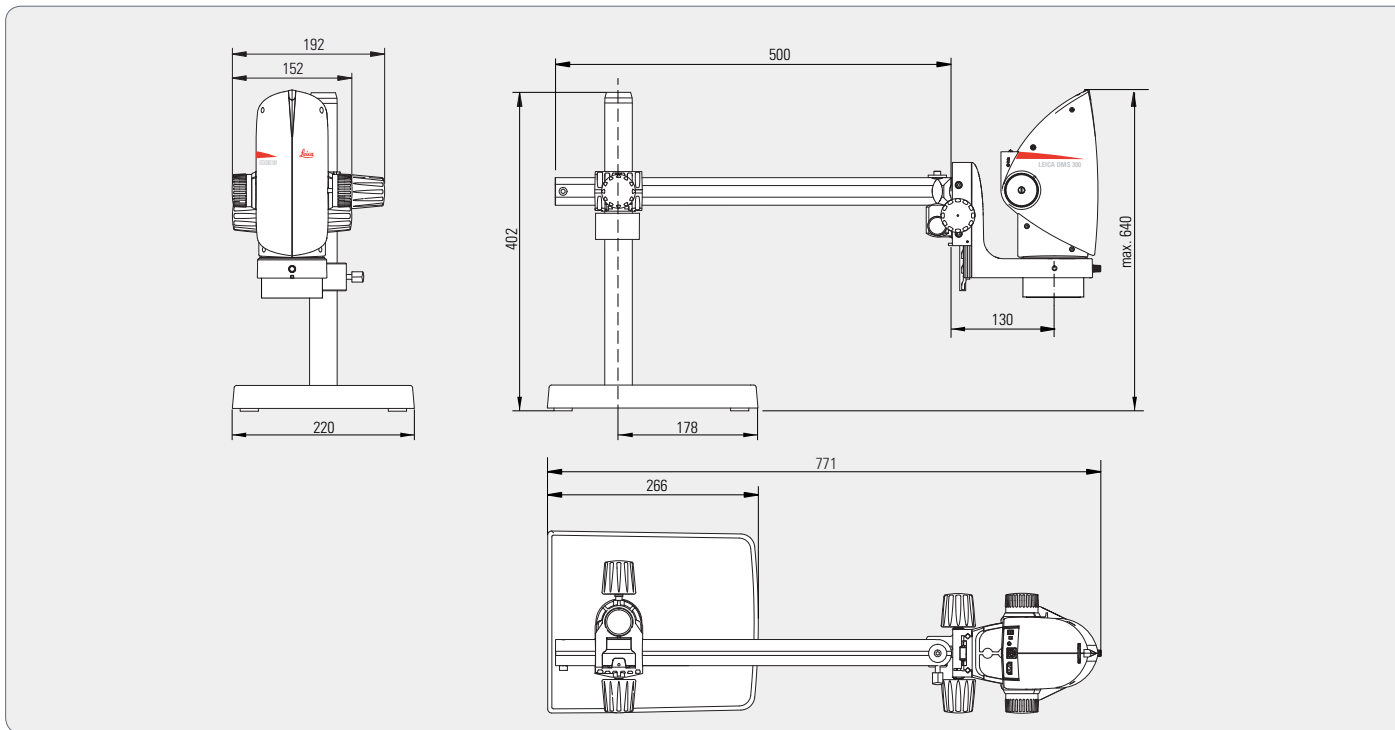

The productive cooperative effort "with the user, for the user" has always been the basis for the innovative strength of Leica Microsystems. On this, we have developed our five corporate values:

pioneering, high-end quality, team spirit, dedication to science, and continuous improvement. We call making these values reality **Living up to Life**.

INDUSTRY DIVISION

The Leica Microsystems Industry Division's focus is to support customers' pursuit of the highest quality end result by providing the best and most innovative imaging systems for their needs to see, measure, and analyze microstructures. Its solutions are used in routine and research industrial applications, in materials science and quality control, in forensic science investigations, and educational applications.

www.leica-microsystems.com

Leica Microsystems – an international company with an experienced worldwide customer service network.

Internationally active		Phone	Fax
Australia · North Ryde	+61	2 8870 3500	2 9878 1055
Belgium · Diegem	+32	2 790 98 50	2 790 98 68
Denmark · Ballerup	+45	4454 0101	4454 0111
Germany · Wetzlar	+49	64 41 29 40 00	64 41 29 41 55
England · Milton Keynes	+44	800 298 2344	1908 246312
France · Nanterre Cedex	+33	811 000 664	1 56 05 23 23
Italy · Milan	+39	02 574 861	02 574 03392
Japan · Tokyo	+81	3 5421 2800	3 5421 2896
Canada · Concord/Ontario	+1	800 248 0123	847 405 0164
Korea · Seoul	+82	2 514 65 43	2 514 65 48
The Netherlands · Rijswijk	+31	70 4132 100	70 4132 109
Austria · Vienna	+43	1 486 80 50 0	1 486 80 50 30
Portugal · Lisbon	+351	21 388 9112	21 385 4668
Sweden · Kista	+46	8 625 45 45	8 625 45 10
Switzerland · Heerbrugg	+41	71 726 34 34	71 726 34 44
Singapore	+65	6779 7823	6773 0628
Spain · Barcelona	+34	93 494 95 30	93 494 95 32
USA · Buffalo Grove/Illinois	+1	800 248 0123	847 405 0164
People's Republic of China · Hong Kong	+852	2564 6699	2564 4163
· Shanghai	+86	21 6387 6606	21 6387 6698

10IDD13060EN_2 · Copyright © by Leica Microsystems (Schweiz) AG, CH-9435 Heerbrugg, 2013. Subject to modifications. LEICA and the Leica Logo are registered trademarks of Leica Microsystems IR GmbH.

Leica
MICROSYSTEMS