

EN

OPERATING MANUAL
ACOUSTIC TUBE PROBE



Table of contents

01 Safety A-1
 02 Intended use A-1
 03 Scope of delivery and overview A-1
 04 Start-up and application A-2
 05 Acoustic leak detection A-5
 06 Pipe and pinpoint location A-6
 07 Troubleshooting A-7
 08 Application examples A-8
 09 Cleaning, storage and transport A-8
 10 Technical data A-9

The measuring device at hand was built according to current state-of-the-art technology and fulfils valid European and national directives. This conformity has been tested and the corresponding declarations and documents are kept on file by the manufacturer. To keep this condition and ensure safe operation, as a user, you must observe the following safety instructions.

01 Safety

We accept no liability for damages caused by non-observance of this manual or unprofessional handling. Any warranty claims are voided in such cases!

▲ Prior to using the LD6000 PTS, this operating manual is to be carefully read and observed in every particular.

For reasons of safety and conformity (CE), any unauthorised change made to the device construction or components which are to be used with the measuring device are prohibited!

- The LD6000 PTS me only be used for drinking water systems. The user is responsible for any other kind of use. Once used in other media, reuse for drinking water is prohibited!
- Observe the storage and operating conditions!
- Before using the LD6000 PTS, always observe the disinfection instructions (see page A-4)!
- The system's maximum operating pressure is 16 bar!
- The maximum bending radius of the probe and the fibre optic cable is 120 mm (which corresponds to 90° for pipes with DN 50). In order to avoid jamming or even cable break, the fibre optic cable is only to be pushed with utmost caution when frequenting bottlenecks.

- The only party responsible for determining measured results to be valid, drawing conclusions and deriving actions is the user! The correctness of the results presented is excluded from any liability or guarantee. Liability for damages which have been caused by utilising the presented measured results is strictly excluded.

02 Intended use

The LD6000 PTS and associated accessories serve the purpose of leak detection in drinking water pipelines. The device may only be used for this intended use while complying with the specified technical data.

03 Scope of delivery and overview

3.1 LD6000 PTS tube probe

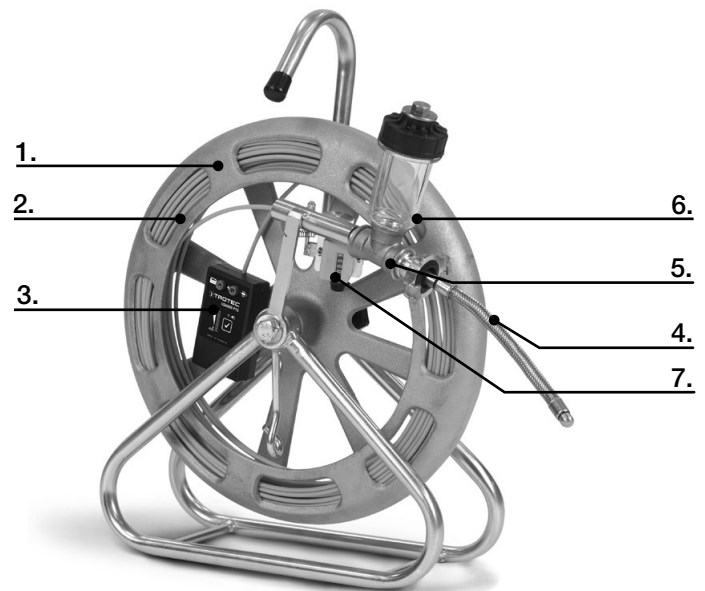

1. Galvanized steel pipe frame with aluminium reel
2. Polykat fibreglass with integrated stranded copper wires
3. Bluetooth transmitter with connection option for a frequency generator
4. Flexible sensor head with precision microphone
5. Pressure-resistant cable passage
6. Storage container with disinfectant
7. Mechanical metre counter for length measurement

3.2 LD6000 PTS accessory case



1. Disinfectant – 250 ml aerosol can
2. Bluetooth headphones
3. GEKA couplings 1 inch internal thread and 1 inch external thread
4. Spare 9 V battery
5. Optional: LD6000 PTS Bluetooth receiver
6. Charging adapters for 230 V socket and 12 V cigarette lighter; mini USB charging cable
7. Hose adapter

3.3 Optional accessories

1. LD6000 combination detector
2. LD6000 PTS Bluetooth receiver
3. Water- and impact-proof Bluetooth speaker
4. SeekTech SR20 and SeekTech ST510 (pipe detector and transmitter)

04 Start-up and application

The LD6000 PTS transmitter unit is running on a customary 9 V battery. The Bluetooth headphones, Bluetooth speaker and Bluetooth receiver are provided with an integrated rechargeable battery. Before start-up make sure that the devices are charged or the battery has sufficient voltage.

Overview of the functions of the LD6000 PTS transmitter unit.



1. 9 mm connectors
2. Battery LED
3. Bluetooth LED
4. Level LED
5. Multi-function button
6. "Mute" LED

The functions of the Multi-function button (5) are described below.

- If the button is pressed for approx. 3 seconds while switched off, the transmitter unit switches on.
- If the button is pressed for approx. 6 seconds while switched off, the last active Bluetooth connection will be deleted. Simultaneously the device switches over into pairing mode (search mode).
- If the transmitter unit is switched on and a Bluetooth connection is established, briefly pressing the button activates the "mute" function (muting). If the "MUTE" LED is illuminated, sound transmission is active. If the LED is not illuminated, the transmission is muted as well. The level indicator is not affected by this.
- To switch the device off, press the button for approx. 3 seconds. All parts of the "Level LED" light up. The device only fully switches off when letting go of the button.

The Battery LED (2) indicates the battery's voltage condition. If the LED is constantly lit, the battery has sufficient voltage. If it flashes slowly, the battery should soon be changed. If it flashes quickly, the voltage is insufficient for another measurement and the battery has to be changed first.

The Bluetooth LED (3) indicates, whether there is a Bluetooth connection. If the LED is constantly lit, a connection is established. If it flashes, the device is in pairing mode (search mode). If it is not illuminated, the connection is not made and the transmitter unit will only reconnect (pair) with the last active connection.

The Level LED (4) indicates the intensity of the recorded sound. Please note that a leaking sound does not necessarily cause a full-scale deflection of the Level LED. The Level LED is only intended for orientation purposes.

The "MUTE" LED (6) indicates, whether the recorded sound is transmitted or the transmission is muted. If the LED is illuminated, the sound is transmitted. If the LED is not illuminated, the transmission is muted.

The two integrated 9 mm connectors (1) serve to connect a frequency generator (e.g. SeekTech transmitter ST510) for pipe detection. If a connector is connected to the generator and at the same time a ground spike is used, the course of the inserted fibre optic cable can be traced. If both connectors (signal and ground) are connected, the search pig at the probe tip is contacted. Thus an exact position for the pig can be determined. The pig was optimized for use with 33 kHz. Other common frequencies can only be used to a limited extent or not at all.

To install the LD6000 PTS in a pipeline to be inspected, please proceed according to the illustrated getting started guide which is supplied with the device. The above mentioned usage is only one example for possible applications. For different application scenarios the procedure is to be analogous. In chapter 8 Application examples you will find further possible uses of the LD6000 PTS.

4.1 Bluetooth connection

In order to transmit the sound recorded by the sensor head, a Bluetooth connection has to be established between the transmitter unit and the headphones, Bluetooth receiver or speaker (optionally available). The pairing mode (search mode) for the corresponding devices is described in tabular form.



4.1.1 Bluetooth transmitter

Bluetooth setting	Control	LED display
Re-establish last Bluetooth connection.	Switch on transmitter (press Multi-function button for 3 s).	Bluetooth LED inactive
Switch Bluetooth into pairing mode (search mode).	Press the Multi-function button for 6 s while switched off.	All level LEDs light up, Bluetooth LED flashes.

Bluetooth setting	Control	LED display
Establishing connection.	Waiting for the other end.	Blue LED flashes.
Bluetooth connection is established.		Bluetooth LED constantly lit.
Connection error		All Level LEDs are flashing (quickly).

4.1.2 Headphones

Bluetooth setting	Control	LED display
Re-establish last Bluetooth connection.	Switch on the device (press power button for 5 s).	Blue LED flashes.
Switch Bluetooth into pairing mode (search mode).	Switch on the device (press power button for 7 s).	Blue and red LEDs are flashing (quickly) in turn.
Establishing connection.	Waiting for the other end.	Blue and red LEDs are flashing (quickly) in turn.
Bluetooth connection is established.		Blue LED flashes every 5 s (slowly).
No connection		Blue LED flashes every 0.5 s (quickly).

4.1.3 Bluetooth receiver (for LD6000, optional)

Bluetooth setting	Control	LED display
Re-establish last Bluetooth connection.	Switch on the device (press power button for 4 s).	Blue LED flashes.
Switch Bluetooth into pairing mode (search mode).	Press the power button for approx. 7 s while switched off.	Blue and red LEDs are flashing (quickly) in turn.
Establishing connection.	Waiting for the other end.	Blue and red LEDs are flashing (quickly) in turn.
Bluetooth connection is established.		Blue LED flashes every 5 s (slowly).
No connection		Blue LED flashes every 1 s (quickly and briefly).

4.1.4 Speaker (optionally available)

Bluetooth setting	Control	LED display
Re-establish last Bluetooth connection.	Switch on the device (press power button for 4 s).	Power LED is illuminated.
Switch Bluetooth into pairing mode (search mode).	Briefly press Bluetooth button.	Bluetooth LED is flashing quickly.
Establishing connection.	Waiting for the other end.	Bluetooth LED is flashing quickly.
Bluetooth connection is established.		Bluetooth LED is illuminated.
No connection		Bluetooth LED is flashing slowly.

4.2 Disinfection – disinfection instructions

⚠ **Before using the LD6000 PTS, all parts coming into direct contact with the drinking water must be disinfected. Proceed according to the following instructions.**

⚠ **Always wear suitable protective gloves (supplied in the accessory case) when filling the storage container or refilling the spray flask.**

The disinfectant is a neutral, liquid cleaning agent based on especially stabilized 3% hydrogen peroxide. It is used for environmentally friendly cleaning and sterilization and approved for use in drinking water systems.

⚠ **No general HAZMAT regulations apply. However, the usual precautions are to be taken when handling chemicals.**

1. First spray a generous amount of disinfectant on the sensor head of the LD6000 PTS and let it sit for approx. 5 minutes.

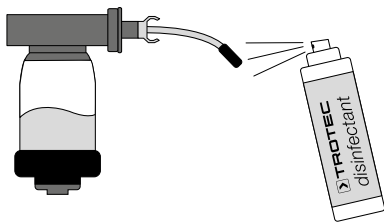

2. Fill the storage container to approx. ¼ with disinfectant.

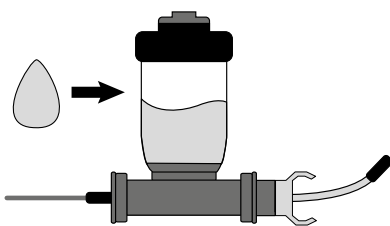

3. When measuring, the storage container is to be positioned vertically at the top to enable a continued flow of the disinfectant.

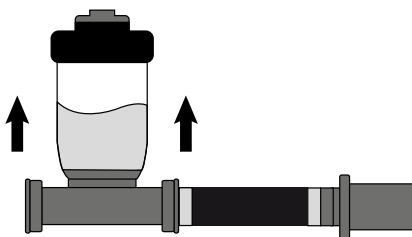

When inserting the fibre optic cable into the pipeline, it is continuously pulled through the disinfectant solution. No specific application time is required during insertion. The agent is pH neutral and after use can be fed into the waste water system without prior neutralization.

4.3 Connection of the LD6000 PTS cable passage

The cable passage is connected for a smooth insertion of the flexible sensor head in the drinking water line. The passage comes with a GEKA coupling approved for use in drinking water systems. Prior to installation the water line must be shut off!

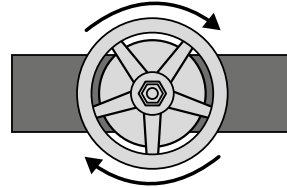

Close the shut-off valve and then prepare the end of the pipe section to be examined with a supplied GEKA coupling. Always connect preferably straight pieces or branches of no more than 45° to avoid the sensitive sensor head getting caught during insertion.

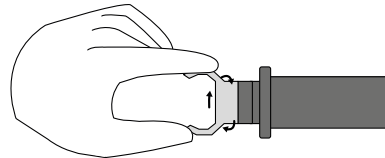

If the distance between the attached GEKA coupling at the pipeline and the next shut-off valve is too small, you should use a hose adapter (supplied in the accessory case) to connect the cable passage.

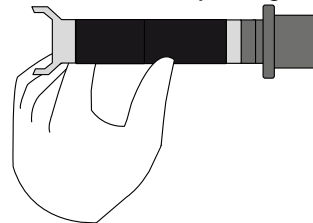

The GEKA coupling is now connected to the pressure-resistant cable passage of the LD600 PTS.

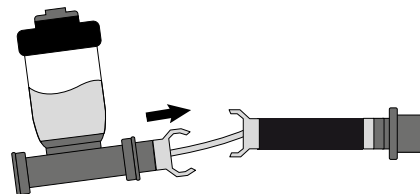

Make sure that the storage container with the disinfectant (see disinfection instructions 4.2) is positioned vertically at the top.

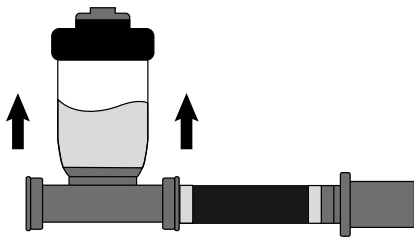

Before inserting the sensor head with the fibre optic cable from the reel, the shut-off valve must again be opened completely.

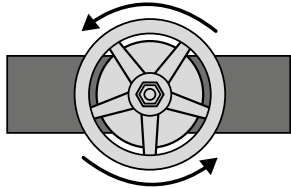

⚠ Before opening the shut-off valve make sure that all connections have been made correctly.

4.4 Insertion of the fibre optic cable

⚠ In case of DN50 pipes the fibre optic cable can be pushed around bends of 90°. Despite this flexibility and the high breaking load, one has to exercise utmost caution during every application with 90° turns.

Should the probe get caught, try loosening it by careful pushing and pulling. In the course of the insertion process a very loud scratching noise will be audible via the headphones/speaker, which is a result of the pushing. This can be suppressed by use of the MUTE function.

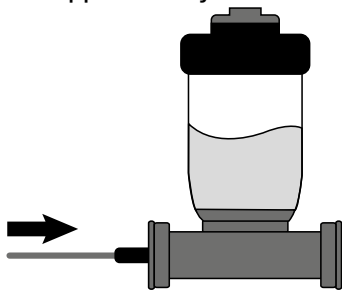

05 Acoustic leak detection

The fibre optic cable with integrated sensor head for audio recording is inserted in the defective pipe. The sound recorder is very sensitive and records even barely perceptible sounds. Nevertheless, despite this sensitivity, it cannot be excluded that a leak is not recognized under certain conditions. This might either be due to the fact that the leak causes no leakage noise or else the sensor head no longer works correctly. Hence, prior to every insertion, check whether the sensor head records the sounds correctly by running your finger down the tip.

It is recommended to insert the fibre optic cable in steps of approx. 30-50 cm. At the end of each step, the probe should be allowed to come to a rest in order to record the sound in the probe's environment.

5.1 Using the Bluetooth headphones

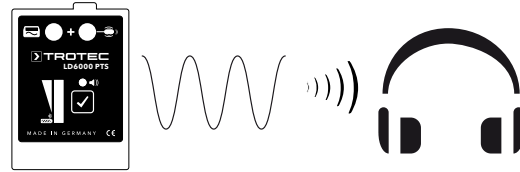

In the case of leak detection using the LD6000 PTS in connection with the Bluetooth headphones, the noisiest spot in the defective pipe is the search target. We proceed on the assumption that every leak brings about a leakage noise. The closer you get to the fault location, the more sound energy will be recorded by the sensor head, which in turn results in a perceptible increase of the volume. At the same time a shift in the pitch to higher frequencies will be audible. Push the probe so far into the pipe until you have detected the noisiest location. For fine tuning push and pull the probe past the leak for a number of times.

5.2 Via integrated level indication

The integrated level indicator at the LD6000 PTS is merely for orientation purposes. Please note that a leaking sound does not necessarily cause a full-scale deflection of the Level LED. On principle, though: the closer the sensor is pushed to the point of leakage, the more noticeable will be the deflection.

5.3 Using the Bluetooth receiver and LD6000 combination detector

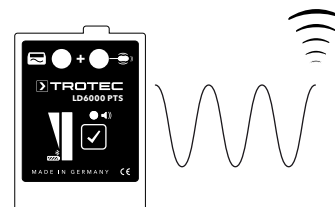
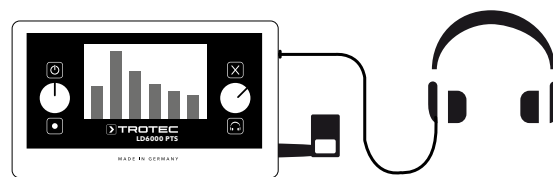

When combined with the LD6000 combination detector the LD6000 PTS is the perfect visual addition for acoustic leak detection. By use of the LD6000 combination detector frequencies to 4000 Hz can be visualized. Optimum results can be achieved in "smart mode" and here in the user-defined application. Also recommendable are non-stop measurements. For details regarding the settings please

read the user manual of the LD6000 combination detector. Fundamentally, here, too: the closer you get to the fault location, the bigger the sound level (numeric indication in the LD6000 combination detector). At the same time a shift in the pitch to higher frequencies will be visible (lower frequency-response diagram in the LD6000 combination detector).

06 Pipe and pinpoint location

Described below are 2 methods to determine the position of the probe head. For one thing by using a common locating device (not included in the scope of delivery) and for another by means of a perambulator.

Method 1 – locating device

A common locating device is required for pipe and pinpoint location (not included in the scope of delivery). Typically such a locating device consists of transmitter and receiver. Read the operating manual of your locating device for proper usage.

After successful acoustic leak detection leave the fibre optic cable at that position in the defective pipe where you detected the maximum level. Then connect the frequency generator of your locating device to the LD6000 PTS.

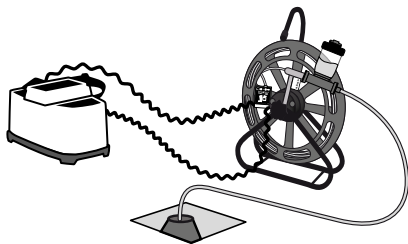

Generally true for all frequency generators of locating devices:

Probe detection

When one connector is connected to the generator and the other to a ground spike stuck into the earth, the course of the inserted fibre optic cable can be traced.

Locating pinpoints

When both connectors (signal and ground) respectively are connected to the generator, only the search pig at the tip of the probe will be contacted. Thus an exact position for the pig can be determined.

The locating function was optimized for the use with 33 kHz, other common frequencies can only be used to a limited extent or not at all.

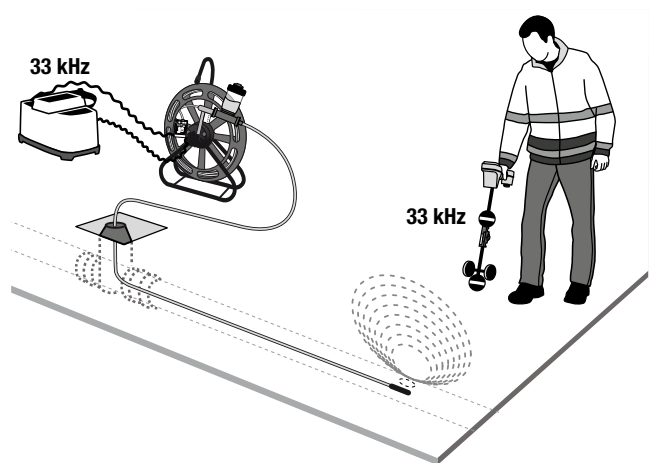

Method 2 – perambulator

After successful acoustic leak detection also leave the fibre optic cable at that position in the defective pipe where you detected the maximum level. Now read the developed uncoiling length from the mechanical metre counter.

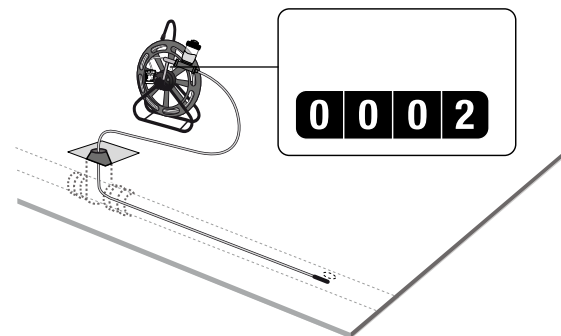

Memorize the value and then walk down the corresponding length with a perambulator. The position, where the values of perambulator and mechanical metre counter coincide, corresponds to the location of the probe head inside the pipe.

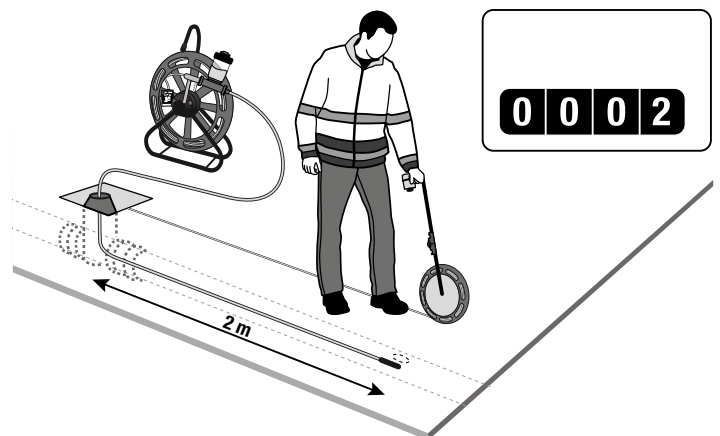

07 Troubleshooting

Fault description	Potential causes	Proposed solution
LD6000 PTS does not connect via Bluetooth using the headphones/ Bluetooth receiver/ speaker (optionally available).	<p>The other end is not switched on.</p> <p>The other end was paired with a different device.</p> <p>Pairing (search mode) was not performed correctly.</p>	<p>Switch on the other end.</p> <p>Refresh the pairing mode (search mode) between LD6000 PTS and headphones/ Bluetooth receiver/ speaker.</p>
Devices cannot locate each other when in pairing mode (search mode).	<p>One of the devices to be paired is not in pairing mode (search mode).</p> <p>The devices are installed too far apart to connect (maximum reach 10 m).</p>	<p>Switch both devices into pairing mode (search mode) and wait for a few seconds until their connection is established.</p> <p>Bring the devices as close as possible to one another during pairing mode (search mode).</p>
Level indication at the LD6000 PTS starts to flash in pairing mode (search mode).	Fault during pairing mode (search mode)	Switch off the LD6000 PTS and perform pairing (search mode) once again.
Connection is suddenly lost during operation.	<p>Headphones/ Bluetooth receiver or speaker positioned too far away from the LD6000 PTS (maximum reach 10 m).</p> <p>Batteries of the LD6000 PTS/ headphones/ Bluetooth receiver or speaker (optionally available) are too low.</p> <p>LD6000 PTS/ headphones/ Bluetooth receiver or speaker have switched off for no reason.</p>	<p>Bring the devices back into the transmission range.</p> <p>Change the battery of the LD6000 PTS or charge headphones/ Bluetooth receiver/ speaker.</p> <p>Switch the device back on.</p>
LD6000 PTS can no longer be switched on / off.	Software bug	Briefly disconnect the battery of the LD6000 PTS Bluetooth transmitter and then reconnect it.
Connection between LD6000 PTS and headphones/ Bluetooth receiver/ speaker (optionally available) is established correctly, but no sound can be heard.	<p>The "mute" function (muting) at the LD6000 PTS is active.</p> <p>Fibre optic cable was damaged or is visibly kinked (cable break).</p> <p>Sensor head was damaged or torn off.</p>	<p>Briefly press the Multi-function button (MUTE LED should be illuminated).</p> <p>Return the device to the manufacturer for repair/inspection.</p>
Locating of the fibre optic cable / probe head is not possible.	<p>The frequency generator is not properly connected to the LD6000 PTS.</p> <p>The pipe is located too deep in the ground or underneath a sealed surface with metal.</p> <p>Fibre optic cable is damaged or broken.</p>	<p>Connect the frequency generator according to this manual.</p> <p>Unfortunately it is not possible to carry out detection here!</p> <p>Return the device to the manufacturer for repair/inspection.</p>

08 Application examples

The following application examples indicate possibilities of how to connect the LD6000 PTS to special built-in elements of the piping system.

8.1 Insertion via domestic water meter

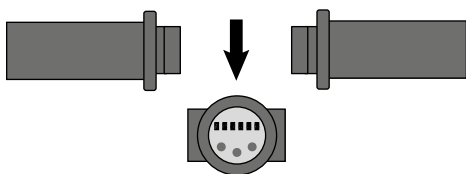

- Shut off the connection.
- Dismount the water meter.
- Affix the GEKA coupling.
- Fasten the hose adapter.
- Connect the cable passage.
- Open the house connection again.
- Insert the probe.

8.2 Insertion via free-flow valve

- Shut off the connection.
- Dismount the free-flow valve.
- Affix the GEKA coupling.
- Fasten the hose adapter.
- Connect the cable passage.
- Open the connection again.
- Insert the probe.

8.3 Insertion via detached pipe

- Put pipeline out of operation.
- Detach the pipe.
- Affix a suitable adapter by use of a GEKA coupling.
- Connect the cable passage.
- Put the pipeline back into service.
- Insert the probe.

8.4 Insertion via hydrant

- Attach adapter for hydrant by means of a GEKA coupling.
- Connect the cable passage.
- Fully open the hydrant.
- Insert the probe.

8.5 Insertion via tapping saddle

- Tap pipeline via a 45° tapping saddle.
- Fix GEKA coupling to valve (saddle).
- Connect the cable passage.
- Completely open the tapping saddle.
- Insert the probe.

09 Cleaning, storage and transport

⚠ The following is to be observed for cleaning, storage and transport of the device.

Cleaning

- Do not use any sharp objects or aggressive chemicals to clean the LD6000 PTS!

Storage

- Always store the disinfectant in an upright position (lid facing up).
- Protect the fibre optic cable from direct sunlight.
- For longer storage disconnect the 9 V battery of the Bluetooth transmitter.
- Store in dry and dust-free surroundings.
- Do not expose to aggressive media.
- Storage temperature 0...40 °C
- Relative humidity 80 %

Transport

- Lock the storage container in place by means of the rubber strap provided at the reel.
- Make sure that the device does not suffer any major impacts during transport.
- For transport in a vehicle observe the road traffic regulations on securing cargo.

10 Technical data

Sensor:

- Highly flexible sensor head
- Integrated antenna (for pinpoint location)
- Sound recorder: frequency range 10 Hz to 10,000 Hz
- IP68 type of protection

Fibre optic cable and reel:

- 4.5 mm Polykat fibreglass
- Breaking load: 10.3 kN
- Maximum bending radius: 120 mm
- Length: up to 70 m
- Aluminium frame
 - dimensions 570 x 400 x 160 mm
 - weight approx. 7 kg
- Mechanical length measuring device
- Transport lock for disinfectant container

Passage:

- Pressure-resistant to max. 16 bar
- GEKA coupling approved for use in drinking water systems
- Disinfectant container

Bluetooth transmitter (integrated in reel):

- IP66 type of protection (exclusive of battery compartment)
- 9 V battery operation
- Bluetooth 2.0, class 2, frequency 2.4 GHz
- Range: 10 m
- Integrated LED level indication
- Battery status indication
- "mute" function (muting)
- 2 x 9 mm banana plug sockets

receiver:

- Bluetooth receiver for LD6000 combination detector
 - integrated Li-ion battery
 - operating hours: approx. 6 h
 - Bluetooth 2.0, class 2, frequency 2.4 GHz
 - range: 10 m

- Bluetooth headphones
 - integrated Li-ion battery
 - operating hours approx. 8 h
 - Bluetooth 2.0, class 2, frequency 2.4 GHz
 - range: 10 m
- Bluetooth speaker (optionally available)
 - integrated Li-ion battery
 - operating hours approx. 8 h
 - Bluetooth 2.0, class 2, frequency 2.4 GHz
 - range: 10 m

Accessory case:

- Disinfectant – 250 ml aerosol can
- Bluetooth headphones
- GEKA coupling 1 inch internal thread and 1 inch external thread
- Spare 9 V battery
- Optional: Bluetooth receiver, charging adapter for 230 V socket and 12 V cigarette lighter
- Mini USB charging cable
- Hose adapter

pipe detection:

- 2 x 9 mm banana plug sockets for connection of the frequency generator
- Stranded copper wires integrated in fibre optic cable for contacting
- Antenna integrated in sensor head for pinpoint location (optimized for 33 kHz)

Trotec GmbH & Co. KG

Grebener Str. 7
D-52525 Heinsberg

☎ +49 2452 962-0

☎ +49 2452 962-200

info@trotec.com

www.trotec.com