

RegA

High Repetition-Rate, Femtosecond Ti:Sapphire Amplifiers

With repetition-rate options to >500 kHz, the RegA 9000/9040/9050 provides a unique range of performance for Ti:Sapphire amplifiers. Its use of CW pumping by the market-leading Verdi laser creates a stable, near diffraction-limited output beam with energy to >6 μJ at 250 kHz. The wavelength range of RegA can also be extended by adding a Coherent high repetition-rate optical parametric amplifier (OPA 9400/9800 series).

The RegA is specifically designed to amplify seed pulses from a Coherent Vitera, Mira or Vitesse. For oscillator/amplifier split-pump beam configurations, the specified pump laser for RegA is our Verdi G10, G12 or G18, The Vitesse Duo, which integrates the seed oscillator and amplifier pump laser into a single package, forms the most compact configuration.

Three versions of RegA are available: the sub-160 fs RegA 9000, the sub-60 fs RegA 9050, and the sub-40 fs RegA 9040. The basic RegA 9000 includes the stretching, amplification and compression functions into a single box. The RegA 9050 and RegA 9040 both use one unit for the amplifier and a second unit containing a stretcher and compressor.

The low noise of the Verdi pump laser and high repetition-rate of RegA amplifiers enable data collection with high signal-to-noise ratio in applications such as fourwave mixing or up-conversion. With hundreds of units installed, the RegA system is a well proven ultrafast tool for advanced ultrafast research.



Superior Reliability & Performance

RegA Features:

- **MCW-pumped regenerative amplifier (Verdi pumping)**
- **High repetition-rate, variable to 300 kHz standard (>500 kHz optional)**
- **Versatile electronic control**
- **Versions to sub-40 fs, >6 μJ**
- **Two box configuration available**
- **Multiple OPA pumping**

RegA Applications:

- **Ultrafast Spectroscopy**
- **Multiphoton Excitation (MPE) Imaging**
- **Material Processing**
- **Waveguide Writing**

RegA

High Repetition-Rate, Femtosecond Ti:Sapphire Amplifiers

Specifications for System Configurations

Specifications for System Configurations	12W Pump ¹		10W Pump ²		Vitesse-Duo ³
	100	250	100	250	100
Repetition-Rate ⁴ (kHz)	100	250	100	250	100
Pulse Energy (μ J)					
RegA 9000 ⁵	5	5	4	3	3
RegA 9000 ⁶	6	6	4	3	3
RegA 9040 ⁷	6	6	4	3	NA
RegA 9050 ⁷	6	6	4	3	NA

RegA Specifications

RegA Specifications	RegA 9000	RegA 9040	RegA 9050
Pulse Width (fs)(FWHM)	<160	<40	<60
Polarization	linear, horizontal, 500:1		
Energy Stability (% rms)	<1		
Average Power Drift ⁸ (% peak-to-peak)	<4		
Contrast Ratio	>500:1 pre-pulse, >250:1 post pulse; other pulses >1000:1		
Beam Quality (M^2)	<2 ⁹	<1.3	<1.5

¹ Assumes full 12W of Verdi power used to pump RegA.

² Assumes full 10W of Verdi power used to pump RegA.

³ Vitesse Duo is an integrated seed-pump source for RegA. Contains internal 10W Verdi split to pump Vitesse seed and RegA. Upper limit for repetition rate is 150 kHz.

⁴ Customer adjustable from 10 kHz to 300 kHz typical.

⁵ RegA 9000 seeded by Mira or Vitesse.

⁶ RegA 9000 used with optional, external stretcher/compressor available at additional cost. Seeded with Vitara-T, Mira or Vitesse.

⁷ RegA 9040 and 9050 designs incorporate external stretcher/compressor and are seeded with Vitara-T.

⁸ Power drift over one hour (after one-hour warm-up); crystal temperature is controlled with supplied chiller, room temperature stable $\pm 1^\circ\text{C}$.

⁹ <1.3 with optional external stretcher/compressor.

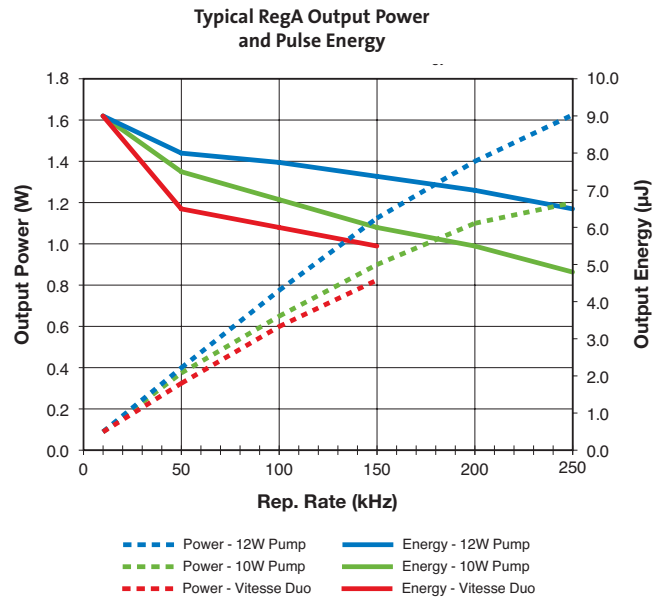
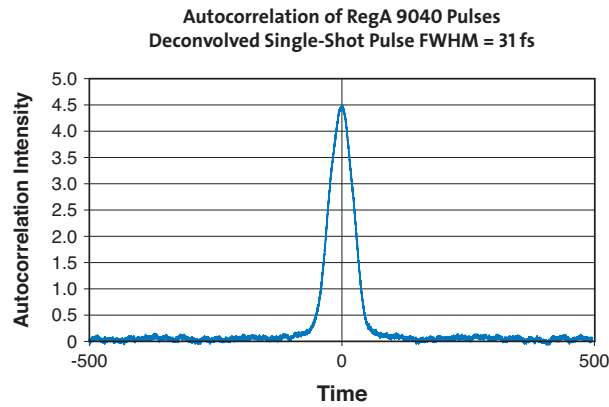

RegA

High Repetition-Rate, Femtosecond Ti:Sapphire Amplifiers

Mechanical Specifications

RegA 9000

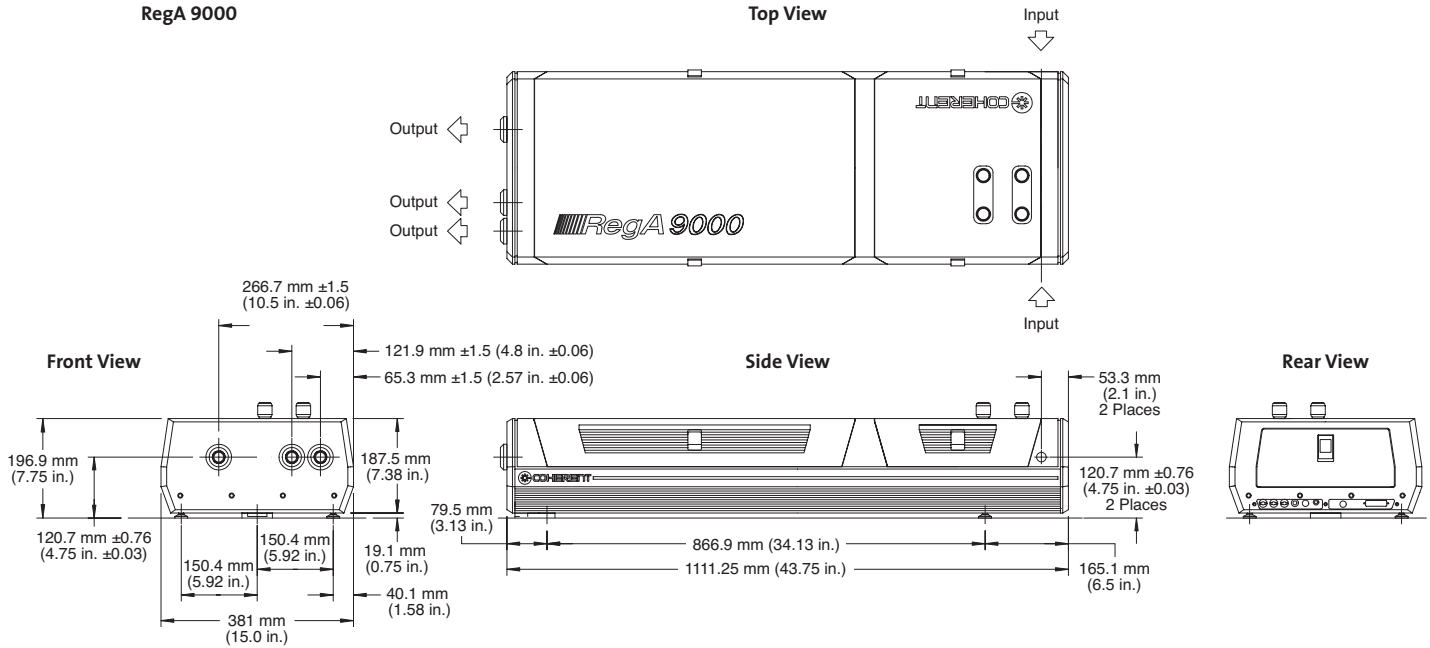

Sample RegA 9050, Vitara, OPA 9850, DFG 9850 Table Layout

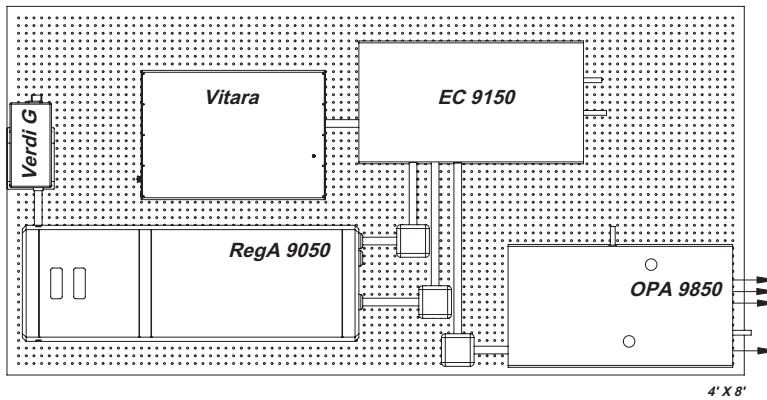

www.Coherent.com

Coherent, Inc.,
 5100 Patrick Henry Drive
 Santa Clara, CA 95054
 phone (800) 527-3786
 (408) 764-4983
 fax (408) 764-4646
 e-mail tech.sales@Coherent.com

Benelux +31 (30) 280 6060
 China +86 (10) 8215 3600
 France +33 (0)1 8038 1000
 Germany/Austria/
 Switzerland +49 (6071) 968 333
 Italy +39 (02) 31 03 951
 Japan +81 (3) 5635 8700
 Korea +82 (2) 460 7900
 Taiwan +886 (3) 505 2900
 UK/Ireland +44 (1353) 658 833

Coherent follows a policy of continuous product improvement. Specifications are subject to change without notice.

Coherent's scientific and industrial lasers are certified to comply with the Federal Regulations (21 CFR Subchapter J) as administered by the Center for Devices and Radiological Health on all systems ordered for shipment after August 2, 1976.

Coherent offers a limited warranty for all RegA amplifiers. For full details of this warranty coverage, please refer to the Service section at www.Coherent.com or contact your local Sales or Service Representative.

