

# Leica LMT260 XY Scanning Stage User Manual

## Contents

<b>General Notes</b>		<b>Instrument Setup</b>	
General Notes	4	Leica LMT260 XY Scanning Stage	25
Important Safety Notes	5	Starting the Leica LMT260 XY Scanning Stage	25
Symbols Used	6	Operating the Leica LMT260 XY Scanning Stage	28
Safety Instructions	7		
<b>Introduction</b>		<b>Service</b>	
Congratulations!	11	Care, Maintenance, Contact People	33
Standard Delivery and Optional Accessories	12	Spare Parts	35
Overview of the Instrument	13		
<b>Assembly</b>		<b>Specifications</b>	
Leica LMT260 XY Scanning Stage with Leica TL5000 Ergo	17	Technical Data	37
Glass Stage Plate and Adapters	17	Dimensional Drawings	39
Leica LMT260 XY Scanning Stage	18	Leica LMT260 XY Scanning Stage	39
Adjusting the Illumination of the Leica TL5000 Ergo Focal Plane	19	HydraDT Control Unit	40
Leica LMT260 XY Scanning Stage with Leica TL4000 Series (BDFD, RC, RCI)	20	CAN Handwheel	41
Glass Stage Plate and Adapters	20		
Leica LMT260 XY Scanning Stage	21		
<b>Installation</b>			
Cables and Terminals	23		



# General Notes

## General Notes

### Safety concept

Before using your Leica LMT260 XY scanning stage for the first time, please read the "Safety Concept" brochure, as well as the user manuals available on the DVD, both included with your instrument. They contain additional information on handling and care.



### Cleaning

- Do not use any unsuitable cleaning agents, chemicals or techniques for cleaning.
- Never use chemicals to clean colored surfaces or accessories with rubberized parts. This could damage the surfaces, and products could be contaminated by abraded particles.
- In most cases, Leica Microsystems can provide special solutions on request. Some products can be modified, and we can offer special accessories for use in clean rooms.

### Servicing

- Repairs may only be carried out by Leica Microsystems trained service technicians. Only original Leica Microsystems spare parts may be used.

### Responsibilities of the person in charge of the instrument

- Please ensure that the Leica product is operated, maintained and repaired by authorized and trained personnel only.



## Important Safety Notes

### User manual

The Leica LMT260 XY scanning stage can be set up in a variety of ways in the Leica product range. You can find information on individual system components on the DVD together with all relevant user manuals in additional languages. Please keep this DVD in a safe place, where it is available to all users.

This user manual describes the special functions of the Leica LMT260 XY scanning stage and contains important instructions for its operational safety, maintenance, and accessories.

The "Safety Concept" booklet and the user manuals available on the DVD contain additional safety information regarding the service work, requirements and the handling of the Leica LMT260 XY scanning stage, accessories and electrical accessories as well as general safety instructions.

You can combine individual system articles with articles from external suppliers (e.g. cold light sources, etc.). Please consult the supplier's user manual and the safety instructions.

Before installing, operating or using the instruments, read the user manuals listed above. In particular, please follow all safety instructions.

To maintain the unit in its original condition and to ensure safer operation, the user must follow the instructions and warnings contained in these user manuals.



## Symbols Used

### Warning! Safety hazard!



This symbol indicates especially important information that is mandatory to read and observe.

Failure to comply can cause the following:

- Hazards to personnel
- Functional disturbances or damaged instruments

### Warning of hazardous electrical voltage



This symbol indicates especially important information that is mandatory to read and observe.

Failure to comply can cause the following:

- Hazards to personnel
- Functional disturbances or damaged instruments

### Danger due to hot surface



This symbol warns against touching hot surfaces, e.g. those of light bulbs.

### Important information



This symbol indicates additional information or explanations that are intended to provide clarity.





## Safety Instructions

### Description

- The individual modules fulfill the highest requirements for observation and documentation with the Leica LMT260 XY scanning stage.

### Intended use

- See "Safety Concept" booklet and the user manuals available on the DVD.

### Non-intended use

- See "Safety Concept" booklet and the user manuals available on the DVD.

Neither the Leica LMT260 XY scanning stage nor its components may be used for surgical procedures, since they are not intended for that purpose.

The instruments and accessories described in this User Manual have been tested for safety and potential hazards. The responsible Leica affiliate must be consulted whenever the instrument is altered, modified or used in conjunction with non-Leica components that are outside of the scope of this manual.

Unauthorized alterations to the instrument or noncompliant use shall void all rights to any warranty claims.

### Place of use

- See "Safety Concept" booklet and the user manuals available on the DVD.
- Electrical components must be placed at least 10 cm away from the wall and from flammable substances.
- Avoid large temperature fluctuations, direct sunlight and vibrations. These conditions can distort measurements and micro-graphic images.
- In warm and warm-damp climatic zones, the individual components require special care in order to prevent the growth of fungus.



#### **Responsibilities of person in charge of instrument**

- See "Safety Concept" booklet and the user manuals available on the DVD.

Ensure that:

- ...the Leica LMT260 XY scanning stage and accessories are operated, maintained and repaired by authorized and trained personnel only.
- ...all operators have read, understood and will observe this user manual, and particularly the safety regulations.

#### **Repairs, service work**

- See "Safety Concept" booklet and the user manuals available on the DVD.
- Only original Leica Microsystems spare parts may be used.
- Avoid contact with powered electrical circuits, which can lead to injury.

#### **Transport**

- Use the original packaging for shipping or transporting the individual modules of the Leica LMT260 XY scanning stage and the accessory components.
- In order to prevent damage from vibrations, pack all moving parts that (according to the user manual) can be assembled and disassembled by the customer in their original transport packaging and ship them appropriately.







#### **Integration in third-party products**

- See "Safety Concept" booklet and the user manuals available on the DVD.

#### **Disposal**

- See "Safety Concept" booklet and the user manuals available on the DVD.

#### **Legal regulations**

- See "Safety Concept" booklet and the user manuals available on the DVD.

#### **EC Declaration of Conformity**

- See "Safety Concept" booklet and the user manuals available on the DVD.

#### **Health risks**

Workplaces with microscopes facilitate and improve the viewing task, but they also impose high demands on the eyes and holding muscles of the user. Depending on the duration of uninterrupted work, asthenopia and musculoskeletal problems may occur. For this reason, appropriate measures for reduction of the workload must be taken:

- Optimal arrangement of workplace, work assignments and work flow (changing tasks frequently).
- Thorough training of the personnel, giving consideration to ergonomic and organizational aspects.

The ergonomic optical design of Leica microscopes and design of the Leica LMT260 XY scanning stage are intended to reduce the exertion of the user to a minimum.





# Introduction

## Congratulations!

Congratulations on purchasing the Leica LMT260 XY scanning stage by Leica Microsystems. The Leica LMT260 XY turns your Leica microscope into a universal, highly versatile tool for viewing and documenting microscopic objects or several objects simultaneously in a sample holder.

### **Leica LMT260 XY Scanning Stage**

The Leica LMT260 XY scanning stage provides for direct positioning in two axes by means of linear motors. In addition, an absolute measurement of the stage position occurs, thereby eliminating the need for referencing after switching on. The flat assembly enables ideal accessibility to the object and the control elements of the microscope.

A slide may be easily and precisely moved manually at any time by activating the Leica LMT260 XY scanning stage.

In addition, the Leica LMT260 XY scanning stage features high-precision positionability, repeatability and minimal processing noise.

### **External CAN Handwheel**

The ergonomically designed, dynamic CAN handwheel is equipped with precision roller bearings as well as a high-precision, magnetic measuring system, thereby offering high resolution to control the stage precisely.

The CAN handwheel speed can be varied by means of two switches and is optimized for both left-hand and right-hand operation.

### **External Control Unit HydraDT**

Using the external control unit HydraDT, five Leica LMT260 XY scanning stage positions can be stored and automatically recalled by pressing a button.

The zero position (center position) of the Leica LMT260 XY scanning stage can also be automatically recalled by pressing a button.



## Standard Delivery and Optional Accessories

### Standard delivery

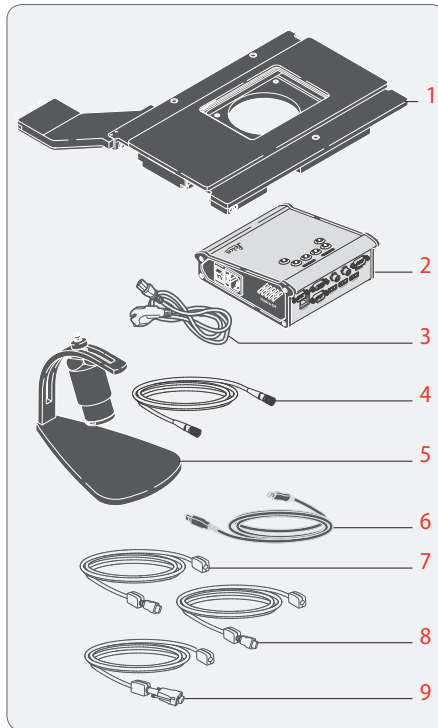

The Leica LMT260 XY scanning stage's standard delivery includes:

- 1 Leica LMT260 XY scanning stage
- 2 External control unit HydraDT
- 3 Power cable
- 4 CAN cable
- 5 External CAN handwheel
- 6 USB cable
- 7 HDMI cable (sensor X) (fixed onto the stage)
- 8 HDMI cable (sensor Y) (fixed onto the stage)
- 9 Motor X+Y-cable (fixed onto the stage)

### Optional accessories: Adapter plates

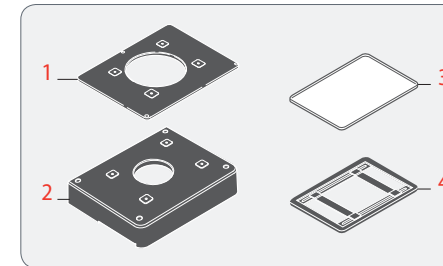

- 1 Adapter plate for the Leica TL5000 Ergo transmitted light base
- 2 Adapter plate for the Leica TL4000 series (RCI, RC & BFDf)
- 3 Glass stage plate
- 4 Live on Stage sample holder 160 x 110 mm  
Additional sample holders are available in dimensions 160 x 110 mm, information available upon request or in the Leica Live on Stage sample holder brochure.



## Overview of the Instrument

Leica LMT260 XY Scanning Stage

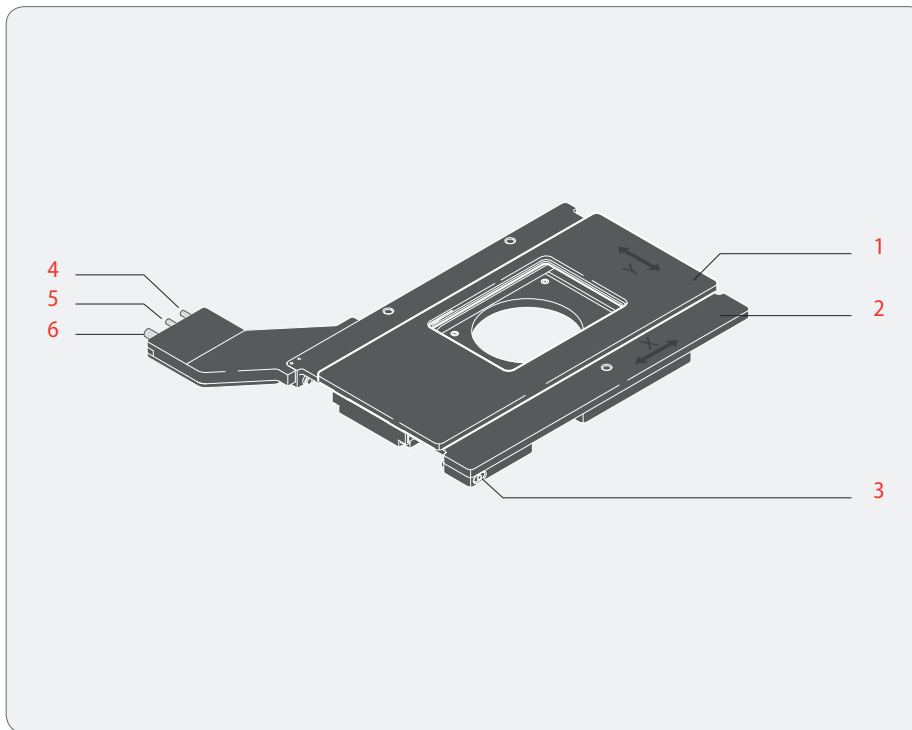

- 1 Transport carriage Y
- 2 Transport carriage X
- 3 Push button with integrated status light
- 4 HDMI cable (sensor X)  
HDMI cable fixed onto the stage
- 5 HDMI cable (sensor Y)  
HDMI cable fixed onto the stage
- 6 Connection for motor X+Y-cable  
Motor X+Y-cable fixed onto the stage





### External Control Unit HydraDT

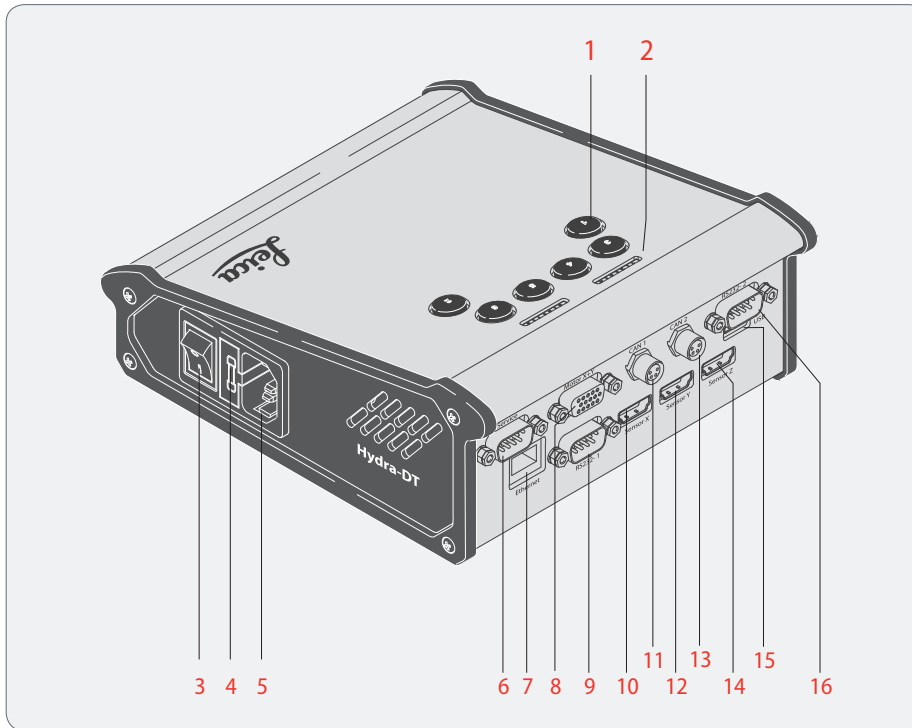

- 1 Push buttons 1-6
- 2 LED status displays 1-8
- 3 On/off switch
- 4 Cover for power socket F3.15A
- 5 Power supply connection
- 6 Service connection
- 7 Network connection, no function
- 8 Connection for motor X+Y-cable
- 9 Connection for RS232-1, no function
- 10 HDMI port (sensor X)
- 11 CAN1 connection
- 12 HDMI port (sensor Y)
- 13 CAN2 connection
- 14 HDMI port (sensor Z), no function
- 15 USB connection
- 16 Connection for RS232-2, no function





### CAN Handwheel

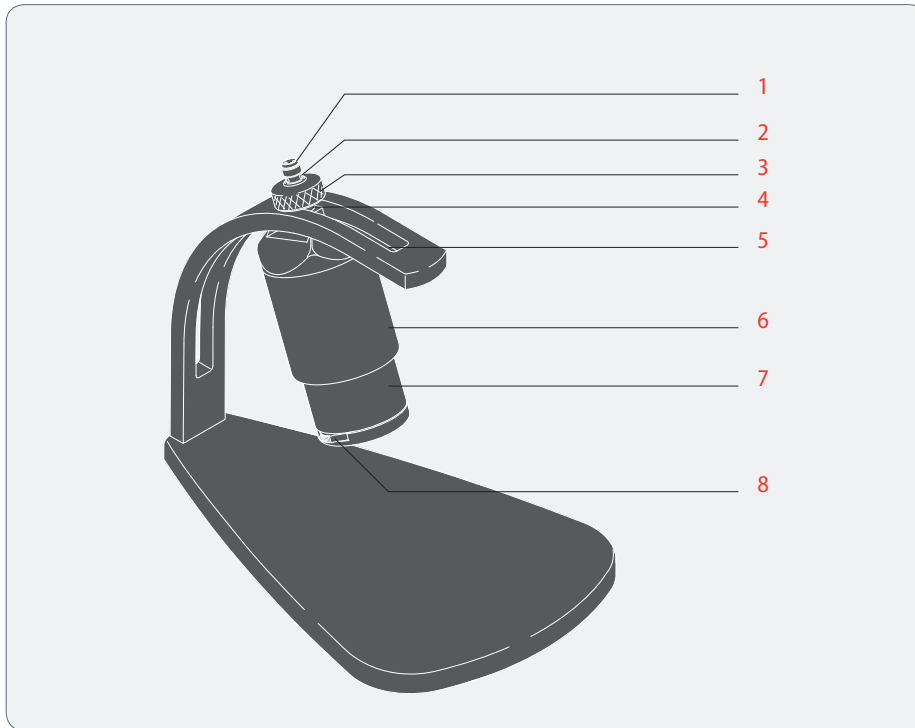

- 1 CAN connection
- 2 LED below the CAN connection  
*LED illuminated red: initializing*  
*LED no longer illuminated: ready to operate*
- 3 Clamping screw
- 4 Shim
- 5 Retaining stirrup
- 6 Setting wheel for controlling the Y-axis
- 7 Setting wheel for controlling the X-axis
- 8 Right and left toggle switch for setting the minimum or maximum speed for both axes



# Assembly







## Leica LMT260 XY Scanning Stage with Leica TL5000 Ergo

### Glass Stage Plate and Adapters

#### General notes

 This chapter shows an example of assembly of the Leica LMT260 XY scanning stage on a transmitted light base.

 The Leica LMT260 XY scanning stage is a precision instrument. During installation, avoid subjecting the stage to impact or severe vibrations.

#### Remove the glass stage plate

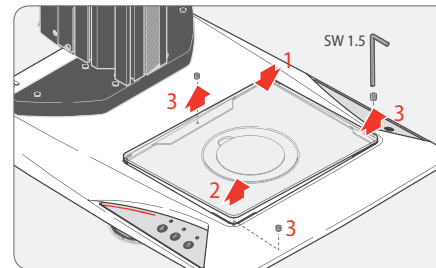

1. Press the glass stage plate downward as shown.
2. Remove the glass stage plate.
3. Loosen and remove the three set screws with a 1.5 mm Allen key.

#### Fit the adapter

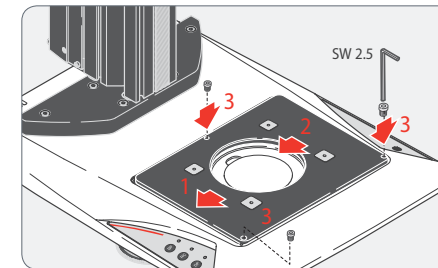

1. Mount the extension plate as shown.
2. Push the extension plate to the left using gentle pressure. Ensure that the extension plate holes are positioned over the threads of the base.
3. Fasten the extension plate with three M3x6 Allen screws using a 2.5 mm Allen key.



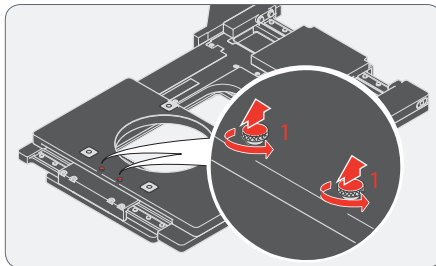

## Leica LMT260 XY Scanning Stage

### Remove the transport anchor



1. Remove the transport anchor screws.

 Secure the axes with your fingers for the following steps, so as not to jam the axes by the movements of the Leica LMT260 XY scanning stage.

 Keep the safety screws; they are needed for retransporting the stage. Do not transport the stage without first installing the safety screws.

### Mount the Leica LMT260 XY scanning stage

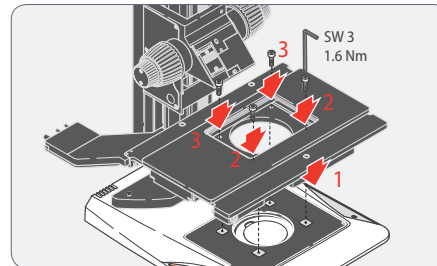

1. Place the Leica LMT260 XY scanning stage to fit precisely on the adapter plate.
2. Gently tighten both front M4x12 Allen screws with a 3 mm Allen key.
3. Gently tighten both rear M4x12 Allen screws with a 3 mm Allen key.
4. To guarantee a high level of precision for the stage, tighten the four screws crosswise exactly 1.6 Nm using a torque wrench.

### Mount the glass stage plate (optional)

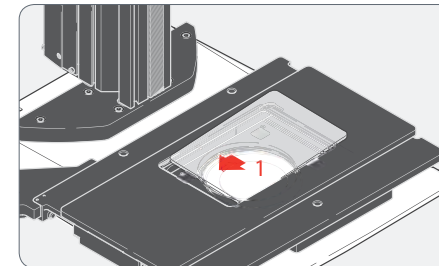

1. Mount the glass stage plate (optional) or the Leica Live on Stage sample holder (optional) as shown.





## Adjusting the Illumination of the Leica TL5000 Ergo Focal Plane

### Activate the menu selection

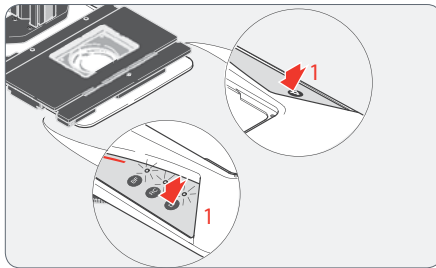

Follow these steps to adapt the illumination of the Leica TL5000 Ergo focal plane to the additional height of the Leica LMT260 XY scanning stage:

1. Press and hold the "DF" and "Light on/off" buttons for 10 seconds. The "BF", "RC" and "DF" LEDs flash three times synchronously, then just one LED flashes to display the selected mode.

### Select RC mode

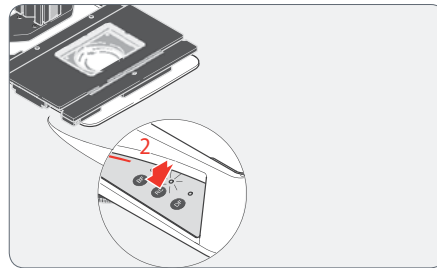

2. Press the "RC" button to adjust the Leica TL5000 Ergo for use with the Leica LMT260 XY scanning stage. The LED for the selected RC mode flashes continuously.



The "BF" mode is designed for use with the motorized/manual Leica IsoPro™ x/y-stage, "DF" for use with the transmitted light base Leica TL5000 Ergo in standalone operation (default setting).

### Save settings

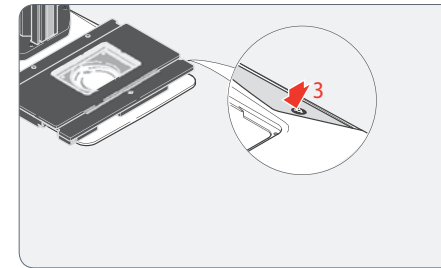

3. Press the "Light on/off" button to save the configured settings and exit the menu selection.



## Leica LMT260 XY Scanning Stage with Leica TL4000 Series (BFDF, RC, RCI)

### Glass Stage Plate and Adapters

#### Remove the glass stage plate

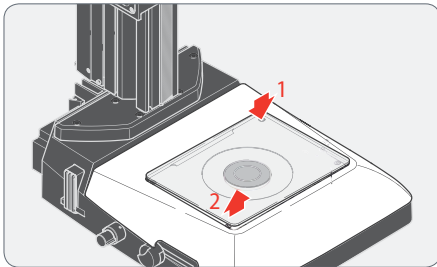

1. Press the glass stage plate downward as shown.
2. Remove the glass stage plate.

 This chapter shows an example of assembly of the Leica LMT260 XY scanning stage on a transmitted light base. Images and descriptions may vary when using another transmitted light base.

 The Leica LMT260 XY scanning stage is a precision instrument. During installation, avoid subjecting the stage to impact or severe vibrations.

#### Remove the standard stage

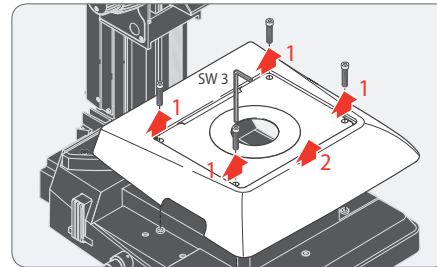

1. Loosen and remove the four Allen screws with a 3 mm Allen key.
2. Remove the standard stage.

#### Install the adapter

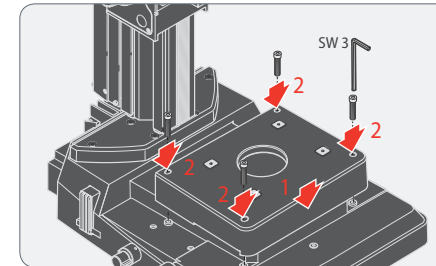

1. Position the adapter exactly.
2. Fasten the adapter with four M4x35 Allen screws using a 3 mm Allen key.



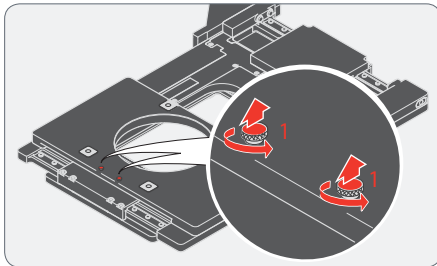

## Leica LMT260 XY Scanning Stage

### Remove the transport anchor



1. Remove the transport anchor screws.

 Secure the axes with your fingers for the following steps, so as not to jam the axes by the movements of the Leica LMT260 XY scanning stage.

 Keep the safety screws; they are needed for retransporting the stage. Do not transport the stage without first installing the safety screws.

### Mount the Leica LMT260 XY scanning stage

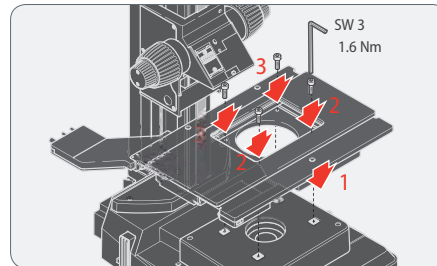

1. Place the Leica LMT260 XY scanning stage to fit precisely on the adapter.
2. Gently tighten both front M4x12 Allen screws with a 3 mm Allen key.
3. Gently tighten both rear M4x12 Allen screws with a 3 mm Allen key.
4. To guarantee a high level of precision for the stage, tighten the four screws crosswise exactly 1.6 Nm using a torque wrench.

### Mount the glass stage plate (optional)

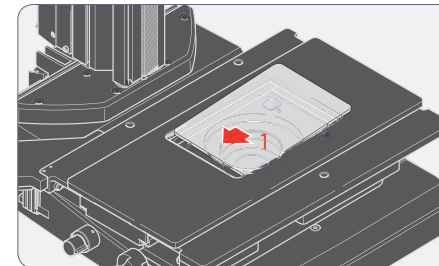

1. Mount the glass stage plate (optional) or the Leica Live on Stage sample holder (optional) as shown.





# Installation



## Cables and Terminals

Leica LMT260 XY scanning stage, HydraDT control unit and CAN handwheel

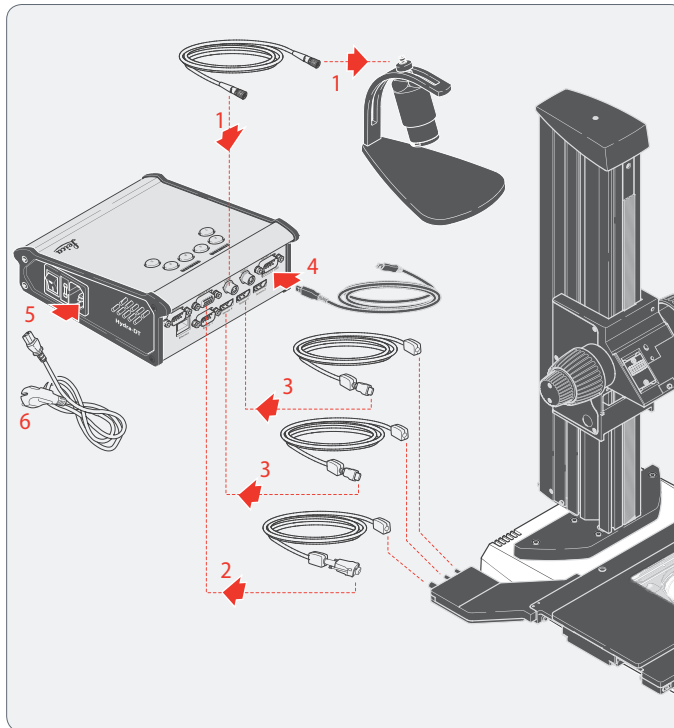

1. Connect the CAN handwheel via the CAN connection to the CAN1 port of the HydraDT control unit using a CAN cable.
2. Connect the Leica LMT260 XY scanning stage to the corresponding port of the HydraDT control unit using a Motor X+Y cable.
3. Connect the Leica LMT260 XY scanning stage to the corresponding HDMI ports of the HydraDT control unit using the HDMI cables (sensor X and sensor Y).
4. To control the Leica LMT260 XY scanning stage using software, connect the USB cable to the corresponding port of the HydraDT control unit and the computer.
5. Connect the power cord to the corresponding port of the HydraDT control unit.
6. Connect the power cable to a grounded socket.

**i** The Leica LMT260 XY scanning stage and the HydraDT control unit are matched to ensure the best possible performance. Using the serial number of the Leica LMT260 XY scanning stage and the adhesive label on the rear side of the HydraDT control unit you can check whether the two instruments are compatible.



# Instrument Setup





# Leica LMT260 XY Scanning Stage

## Starting the Leica LMT260 XY Scanning Stage

### Switching on the HydraDT control unit

 Make sure that all required cables are properly connected and the computer is switched on.

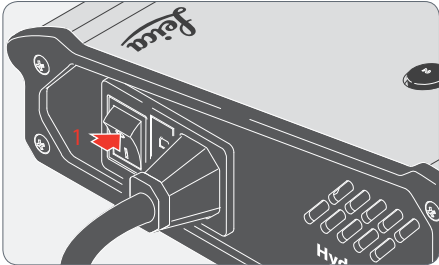

1. Switch on the HydraDT control unit using the on/off switch. This will be confirmed by the LED of status display 8 lighting up (see page 31).
2. The Leica LMT260 XY scanning stage is initialized, which can take up to 30 seconds.
3. As soon as status displays 1 and 2 light up (see page 31), the Leica LMT260 XY scanning stage is ready to operate.
4. Follow the software's instructions for the configuration.





### Setting up Leica Application Suite (LAS)

1. Start the LAS hardware configuration. LAS supports the Leica LMT260 XY scanning stage Version 4.2 and newer.
2. Select "Options" >> "Hardware Setup".

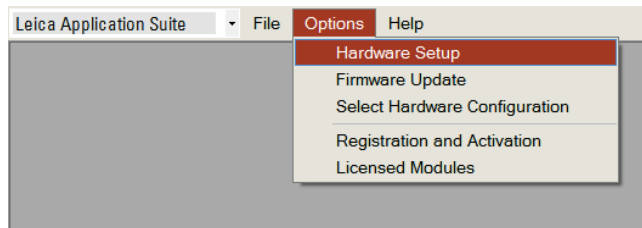

3. At the "Stage" option select "ITK Hydra XY". Now the USB port of the Leica LMT260 XY scanning stage is displayed as COM port. In Windows Device Manager you can see which COM port the Leica LMT260 XY scanning stage is using.
4. Click "Test" to check the configured settings.

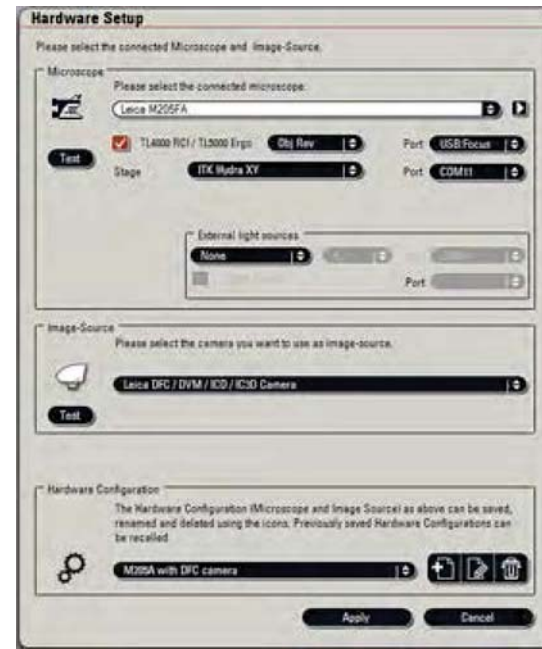

5. Confirm the settings with "Apply".





### Setting up Leica Application Suite Advanced Fluorescence (LAS AF)

1. Start the LAS AF hardware configuration. LAS AF supports the Leica LMT260 XY scanning stage Version 3.2 and newer.
2. Select "Hardware Setup".

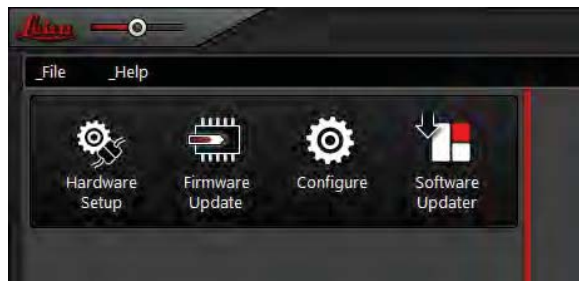

3. At the "External stage" option select "ITK Hydra XY". Now the USB port of the Leica LMT260 XY scanning stage is displayed as COM port. In Windows Device Manager you can see which COM port the Leica LMT260 XY scanning stage is using.
4. Click "Test" to check the configured settings.

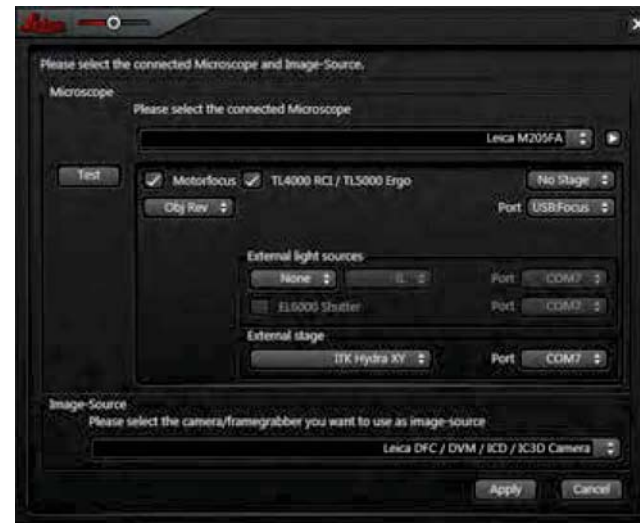

5. Confirm the settings with "Apply".



## Operating the Leica LMT260 XY Scanning Stage

### General notes

The Leica LMT260 XY scanning stage can be operated:

- Using the software (Leica Application Suite or Leica Application Suite Advanced Fluorescence). For additional information, please refer to the corresponding online help.
- With the external CAN handwheel. For additional information, please refer to page 29.
- Directly on the Leica LMT260 XY scanning stage. For additional information, please refer to page 29.
- With the HydraDT control unit. For additional information, please refer to page 30.

### Information about the speed

Speed of the Leica LMT260 XY scanning stage when controlling by means of software: maximum speed = 200 mm/s, maximum acceleration = 100 mm/s<sup>2</sup>



Selection of the minimum or maximum speed on the CAN handwheel (see page 29) has no effect on the speed of the Leica LMT260 XY scanning stage when controlling by means of software.

### Adjust the external CAN handwheel

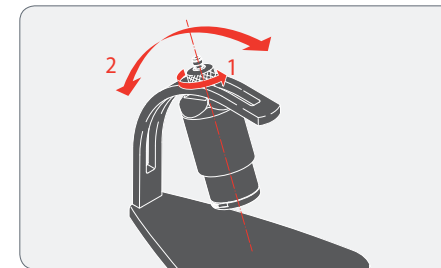

1. Loosen the locking screw.
2. Position the CAN handwheel to match your operating preference and retighten the locking screw.



Make sure that all required cables are properly connected.



### Operating using the CAN handwheel

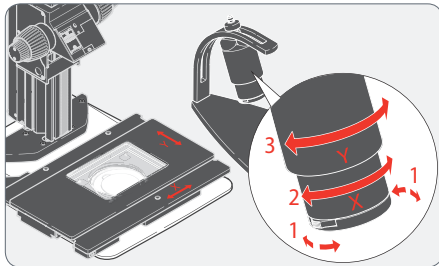

1. Press the toggle switch forward or backward for more than 0.25 seconds to switch between the minimum and maximum speeds of the Leica LMT260 XY scanning stage.
2. Move the Leica LMT260 XY scanning stage in the X direction.
3. Move the Leica LMT260 XY scanning stage in the Y direction.

 For additional information about the minimum or maximum speeds, please refer to page 38.

### Moving the Leica LMT260 XY scanning stage by hand

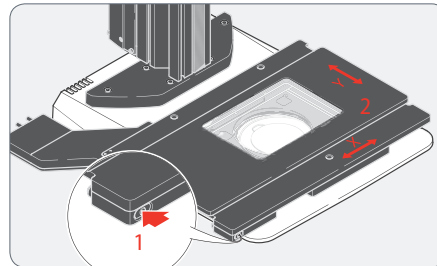

1. If the LED is lit: Press the push button; the Leica LMT260 XY scanning stage can be moved freely; the CAN handwheel, HydraDT control unit and software will not function, and the LED flashes.
2. Now the Leica LMT260 XY scanning stage can be carefully moved by hand.
3. Press the button again to refasten the Leica LMT260 XY scanning stage and to control using the CAN handwheel, HydraDT or software again; the LED lights up and stays green.

The green LED of the push button indicates:

- LED off: No power supply or stage is initializing (approx. 30 seconds).
- LED flashes continuously: One or both axes can be moved freely.
- LED is lit continuously: Leica LMT260 XY scanning stage is ready to operate for monitoring by means of software, CAN handwheel or HydraDT control unit.







### Operating using the HydraDT control unit

Saving a position of the Leica LMT260 XY scanning stage on one of the push buttons 2-6.

1. Approach the desired position.
2. Press the desired push button for more than three seconds:
  - The corresponding coordinates (X and Y) are saved.
  - A successful save is indicated by the corresponding status display flashing three times.

 Saved coordinates are retained until overwritten by another save operation.

 The saved coordinates are the target coordinates of the last motorized movement. If the stage is unlocked during the save, what is saved is not the current position, but instead the last position approached with the motor!

Functions of the push buttons

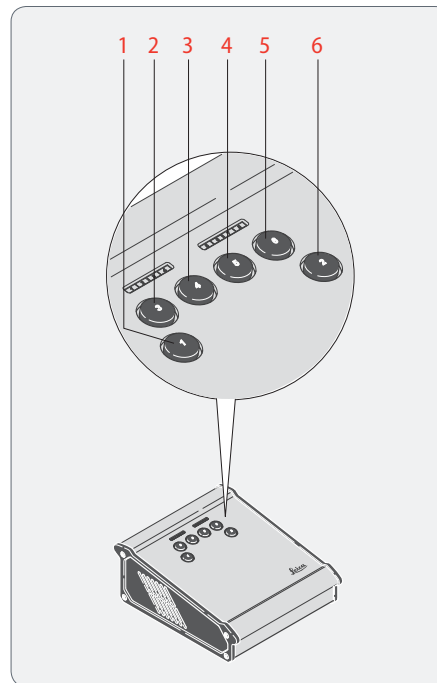

- 1 *Push button 1*  
To approach the zero position (center position)
- 2 *Push button 3*  
To approach or save position 1
- 3 *Push button 4*  
To approach or save position 2
- 4 *Push button 5*  
To approach or save position 3
- 5 *Push button 6*  
To approach or save position 4
- 6 *Push button 2*  
To approach or save position 5

 Five positions can be saved with push buttons 2 to 6. These positions are not identical with the saved positions that can be saved via the LAS or LAS AF software.





### Operating using the HydraDT control unit, continued

Function of status displays 1-8:

- Status displays 3-7 are assigned to savable positions 1-5 or push buttons 2-6.
- Status displays 1-8 illuminate continuously as soon as the Leica LMT260 XY scanning stage is ready to operate.
- If the corresponding push button for saving a position is pressed for more than three seconds, the LED goes out briefly.
- A successful save is indicated by the corresponding LED flashing three times.
- If the corresponding push button is pressed briefly (less than three seconds), the LED flashes once and the last-saved position is approached. No new position is saved.

Status displays

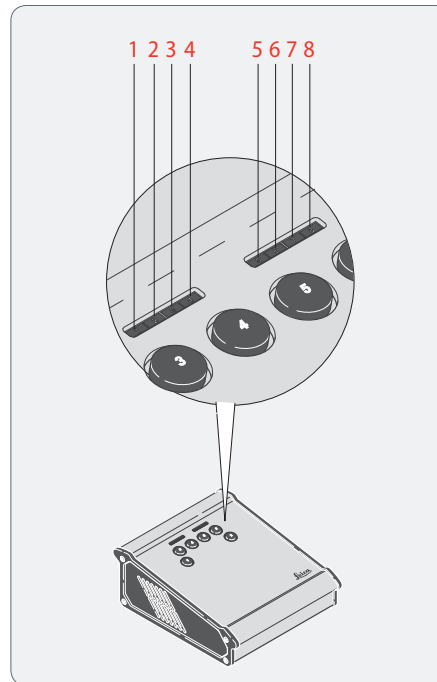

- 1 Status display 1  
*LED on: X-axis fixed*  
*LED off: X-axis free*
- 2 Status display 2  
*LED on: Y-axis fixed*  
*LED off: Y-axis free*
- 3 Status display 3  
*saved position 1/push button 3*
- 4 Status display 4  
*saved position 2/push button 4*
- 5 Status display 5  
*saved position 3/push button 5*
- 6 Status display 6  
*saved position 4/push button 6*
- 7 Status display 7  
*saved position 5/push button 2*
- 8 Status display 8  
*LED lights up and stays green: Operating voltage is present*



# Service







## Care, Maintenance, Contact People

### General

We hope you enjoy using your scanning stage. Leica products are renowned for being robust and for their long service life. Observing the following care and cleaning tips will ensure that even after decades your Leica scanning stage will continue to work as well as it did on the very first day.

### Warranty benefits

The guarantee covers all faults in materials and manufacture. It does not, however, cover damage resulting from careless or improper handling.

### Contact address

If your instrument no longer works perfectly, please contact your Leica Microsystems representative. You can find information on worldwide representatives on the Leica Microsystems website:

[www.leica-microsystems.com](http://www.leica-microsystems.com)

### Care

- For good optical results it is important to keep all optical components clean.
- If any optical surface becomes badly coated with dust or dirt, flush the surface using a syringe or by brushing it off with a camel hair brush before attempting to wipe it clean.
- Optical surfaces should be cleaned using a lint-free cloth, lens cloth or cotton swab soaked in pure ethanol or a commercially available glass cleaner.
- Avoid excessive use of solvents. The lint-free cloth, lens cloth or cotton swab should be soaked with solvent, but not so wet that solvent runs over the lens.
- Protect your microscope from moisture, fumes and acids and from alkaline, caustic and corrosive materials, and keep chemicals away from the instruments.
- Plugs, optical systems and mechanical parts must not be disassembled or replaced, unless doing so is specifically permitted and described in this manual.
- Protect your microscope from oil and grease.
- Do not grease guide surfaces or mechanical parts.





## Care, Maintenance, Contact People (continued)

### Protection from dirt

Dust and dirt will affect the quality of your results.

- Put an optionally available dust cover over the microscope when it will not be used for a long time.
- Keep accessories in a dust-free place when not in use.

### Cleaning polymer components

Some components are made of polymer or are polymer-coated. They are, therefore, pleasant and convenient to handle. The use of unsuitable cleaning agents and techniques can damage polymers.

### Permitted measures

- Clean the microscope (or parts of it) using warm soapy water, then wipe using distilled water.
- For stubborn dirt, you can also use pure ethanol. When doing so, follow the corresponding safety instructions.
- Remove dust with a pneumatic rubber bulb and a soft brush.
- Clean the objectives with special optics cleaning cloths and pure ethanol.

### Servicing

- Repairs may only be carried out by Leica Microsystems-trained service technicians. Only original Leica Microsystems spare parts may be used.

### Danger of electric shock



Risk of electric shock. Removing the cover of the Leica LMT260 XY scanning stage and the HydraDT control unit exposes electrically live parts, which, if touched, can cause potentially fatal injuries. Have technical service carried out by a Leica Microsystems authorized dealer.





## Spare Parts

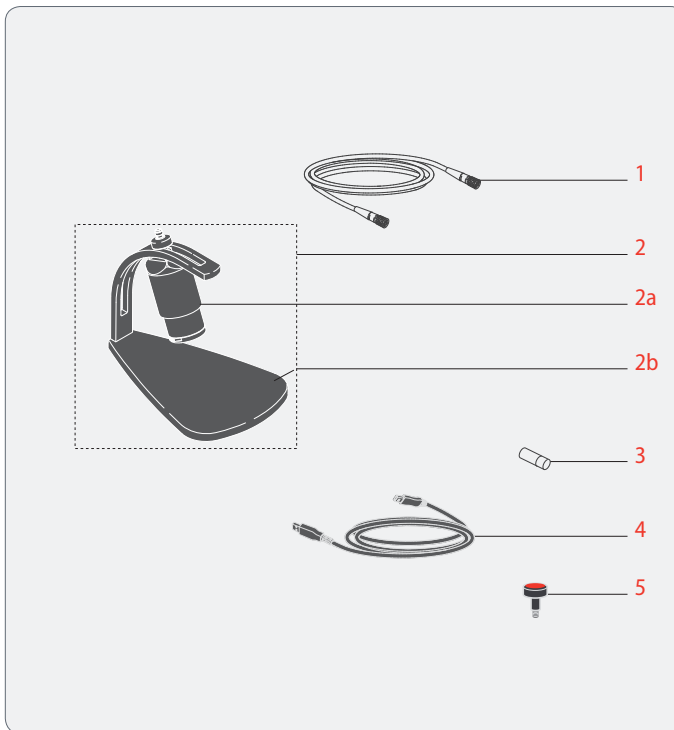

Item	Leica article number	Designation
1	10727010	CAN cable
2	10727011SP	External handwheel
2a	10727012SP	Handwheel
2b	10727013SP	Handwheel stand
3	10727014	CAN terminator
4	10727015	USB cable
5	10727016	Transport anchor screws





# Specifications



## Technical Data

### Leica LMT260 XY scanning stage

Parameter	Item			Notes
Max. loading weight	< 0.5 kg	1.0 kg	1.5 kg (max.)	
Max. acceleration (X/Y)	1.0/2.0 m/s <sup>2</sup>	1.0/2.0 m/s <sup>2</sup>	0.1/0.1 m/s <sup>2</sup>	
Min. acceleration (X/Y)	1 μm/s <sup>2</sup>			
Max. travel speed	500 mm/s	500 mm/s	200 mm/s	Limited by the possible acceleration and the positioning range
Min. travel speed	100 mm/s			
Travel range (X-axis x Y-axis)	120 x 80 mm			
Positioning resolution	5 nm			At 20 °C
Positioning accuracy	< ± 1.0 μm	< ± 2.0 μm	< ± 4.0 μm	At 20 °C
Position repeatability	≤ ± 0.25 μm	< ± 0.5 μm	< ± 1.0 μm	At 20 °C
Peak force	10 N			
Nominal force	8 N			
Dimensions	374 x 247 x 31.1 mm			Without connections
	438 x 367 x 31.1 mm			With connections
Operating voltage	100 to 240 V AC, 50/60 Hz			Power supply voltage
Internal power supply	24 V DC			
Weight	approx. 4.8 kg			
Operating temperature	+10 to +40 °C			





#### HydraDT control unit

Parameter	Item
Operating temperature	+10 to +40 °C
Storage temperature	-20 to +70 °C
Power supply (max.)	100 to 240 V AC, 50/60 Hz
Max. power consumption	P max = 160 W
Weight	approx. 1.1 kg

#### CAN handwheel

Parameter	Item
Operating temperature	0 to +40 °C
Storage temperature	-20 to +50 °C
Power supply (max.)	0 to 36 V
Power output	1.1 W
Weight	1.6 g
Maximum speed	
Setting wheel (gear)	5 mm/turn
Max. speed (Leica LMT260 XY scanning stage)	50 mm/s
Max. acceleration (Leica LMT260 XY scanning stage)	200 mm/s <sup>2</sup>
Minimum speed	
Setting wheel (gear)	0.5 mm/turn
Max. speed (Leica LMT260 XY scanning stage)	2.5 mm/s
Max. acceleration (Leica LMT260 XY scanning stage)	10 mm/s <sup>2</sup>





## Dimensional Drawings

### Leica LMT260 XY Scanning Stage

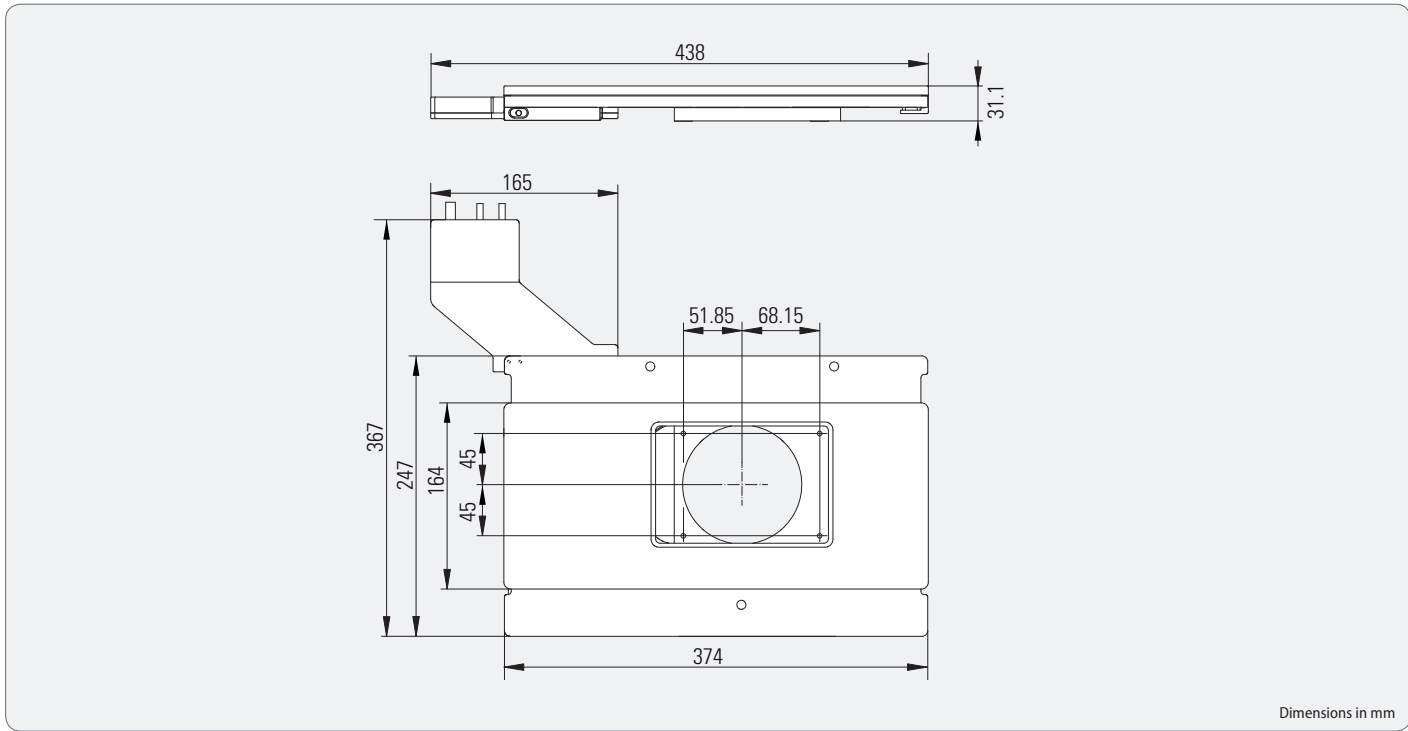



## HydraDT Control Unit

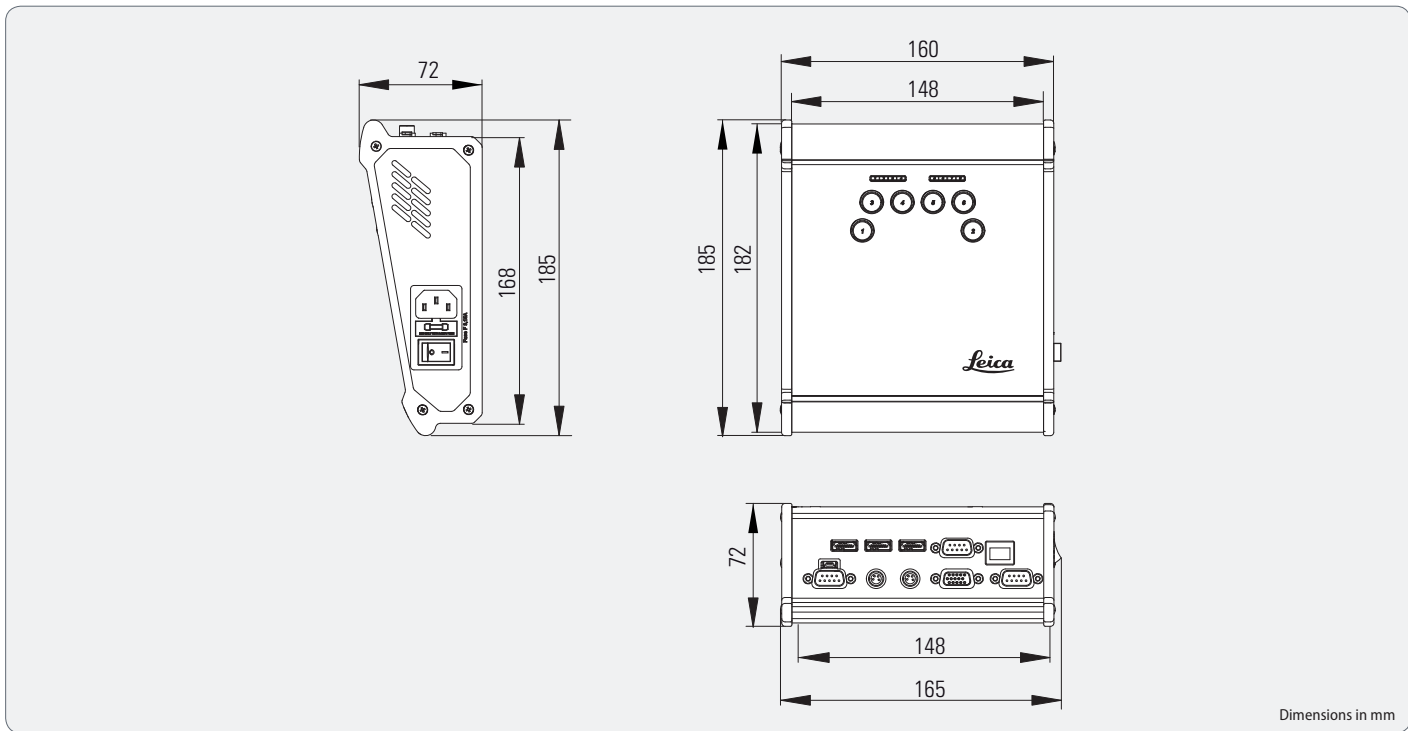





## CAN Handwheel

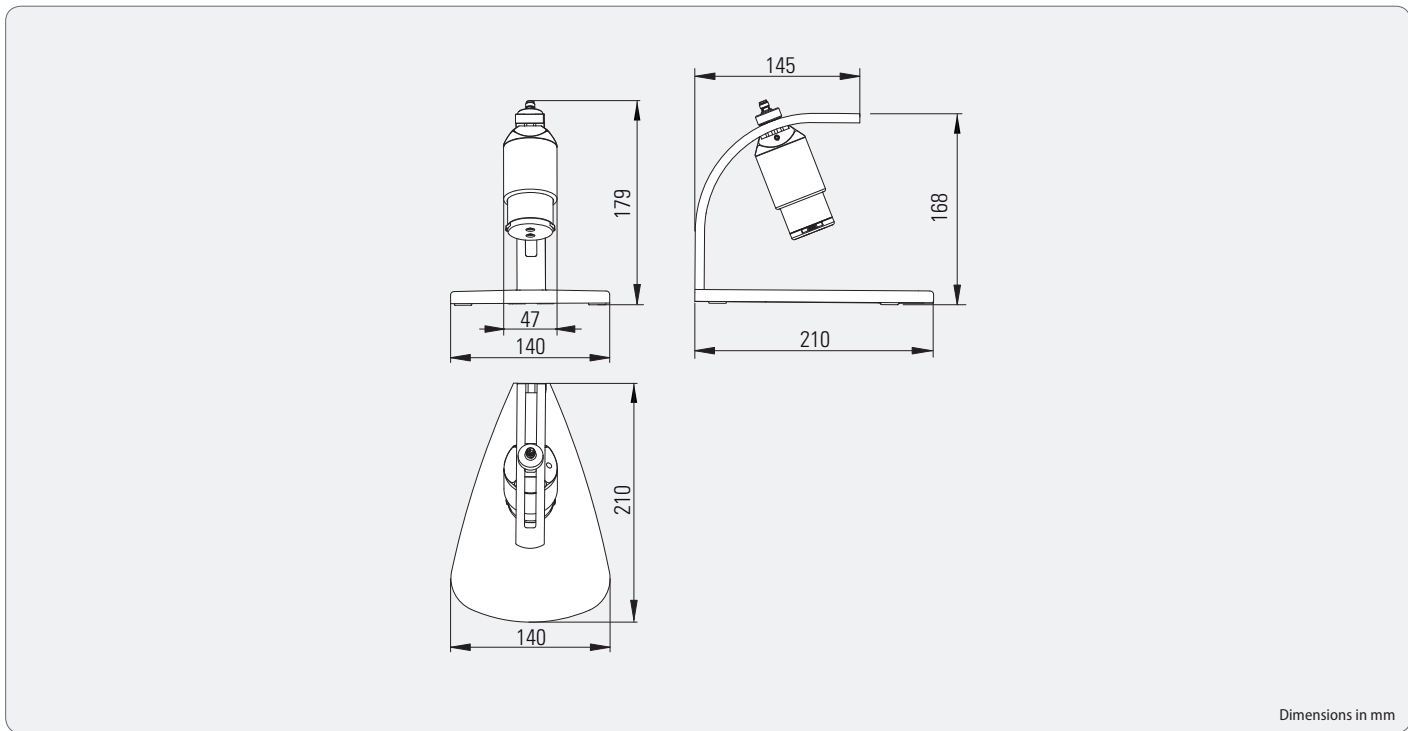

The productive cooperative effort "with the user, for the user" has always been the basis for the innovative strength of Leica Microsystems. On this, we have developed our five corporate values:

pioneering, high-end quality, team spirit, dedication to science, and continuous improvement. We call making these values reality: **Living up to Life.**

#### INDUSTRY DIVISION

The Leica Microsystems Industry Division's focus is to support customers' pursuit of the highest quality end result by providing the best and most innovative imaging systems for their needs to see, measure, and analyze microstructures. Its solutions are used in routine and research industrial applications, in materials science and quality control, in forensic science investigations, and educational applications.

[www.leica-microsystems.com](http://www.leica-microsystems.com)

Leica Microsystems – an international company with an experienced worldwide customer service network.

Internationally active		Phone	Fax
Australia · North Ryde	+61	2 8870 3500	2 9878 1055
Belgium · Diegem	+32	2 790 98 50	2 790 98 68
Denmark · Ballerup	+45	4454 0101	4454 0111
Germany · Wetzlar	+49	64 41 29 40 00	64 41 29 41 55
England · Milton Keynes	+44	800 298 2344	1908 246312
France · Nanterre Cedex	+33	811 000 664	1 56 05 23 23
Italy · Milan	+39	02 574 861	02 574 03392
Japan · Tokyo	+81	3 5421 2800	3 5421 2896
Canada · Concord/Ontario	+1	800 248 0123	847 405 0164
Korea · Seoul	+82	2 514 65 43	2 514 65 48
The Netherlands · Rijswijk	+31	70 4132 100	70 4132 109
Austria · Vienna	+43	1 486 80 50 0	1 486 80 50 30
Portugal · Lisbon	+351	21 388 9112	21 385 4668
Sweden · Kista	+46	8 625 45 45	8 625 45 10
Switzerland · Heerbrugg	+41	71 726 34 34	71 726 34 44
Singapore	+65	6779 7823	6773 0628
Spain · Barcelona	+34	93 494 95 30	93 494 95 32
USA · Buffalo Grove/Illinois	+1	800 248 0123	847 405 0164
People's Republic of China · Hong Kong	+852	2564 6699	2564 4163
· Shanghai	+86	21 6387 6606	21 6387 6698

Order No.: 10IDD12060EN\_2 /23/05/2013 ·

Copyright © 2013 Leica Microsystems (Schweiz) AG, Max Schmidheiny Strasse 201, Heerbrugg, CH-9435 Switzerland. Subject to change.

LEICA and the Leica Logo are registered trademarks of Leica Microsystems IR GmbH.

**Leica**  
MICROSYSTEMS