



Leica DM6000 FS

Modular System

Stand, modules, accessories

Living up to Life

Leica DM6000 FS

Modular System

Status: January 2012

Content

Leica DM6000 FS Base Stand	Page 4
Control Boxes and Trigger Boxes	Page 6
PC and Software	Page 8
System Designs	Page 9
Objective Holders, Objective Changers and Objective Nosepieces	Page 12
Tubes, Magnification Changers and TV Adapters	Page 14
Stages and Specimen Holders	Page 17
Objectives	Page 18
Eyepieces and Graticules	Page 20
Transmitted-Light Contrast Method, Condensers	Page 21
Incident-Light Fluorescence, Filter Cube	Page 27
Light Sources, Lamp Housing, Supply Units	Page 28
Digital Image Documentation	Page 31
Additional accessories	Page 32
Peripherals for Fixed Stage Applications	Page 33
Notes	Page 34

Leica Microsystems CMS GmbH
Ernst-Leitz-Straße
D-35578 Wetzlar (Germany)

Responsible for contents:
Bernard Kleine
(Marketing, Product Management
Life Science Research)



Leica DM6000 FS Base Stand

The Leica DM6000 FS is a research system microscope with motorized and automated functions for electrophysiological applications.

The following contrast methods come into use:

- Bright field
- Phase contrast
- Simple polarization contrast
- Differential interference contrast (DIC)
- Fluorescence

The features: Adjustments of diaphragms and filters as well as adjustments of luminous intensity to the magnification and contrast methods can be carried out and reproduced automatically. The fluorescence illuminator, including filters, diaphragms and shutters, is completely automated.

All motorized functions are controlled and displayed using the Leica STP6000 touch panel.



Fig. 1 Leica DM6000 FS

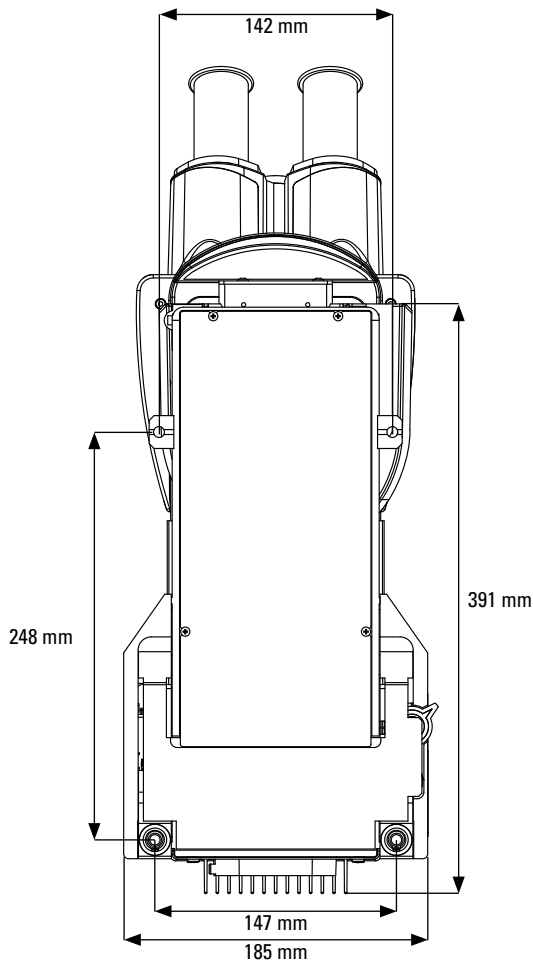

Fig. 2 Footprint

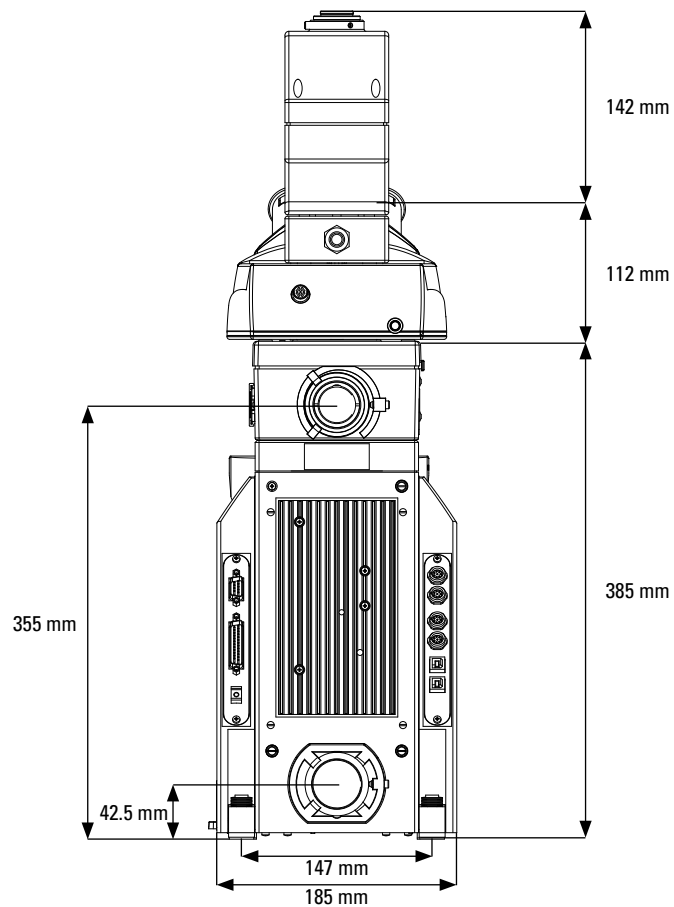

Fig. 3 Rear side

The Leica DM6000 FS Microscope Stand is composed of the following equipment, together having one order number:

Base stand 11 888 928

Consisting of:

Stand base

- Transmitted-light diaphragm module with automatic Constant Color Intensity Control (CCIC), infrared filters 750 – 850 nm and shutter.
- Sealed transmitted-light output.
- Baseplate with manual swing diffuser, which is switched off when the Dodt contrast method is activated.
- Illuminator holder: Leica standard interface for transmitted-light lamp housings.
- 4 mounting holes for fastening to anti-vibration tables or manual or motorized X-Y translation stages for moving the complete microscope.

Rear side of the stand

With various electronic interfaces

- 1 x CTRMIC (external electronics housing)
- 1 x RS232C
- 2 x USB2
- 4 x EXT (for external auxiliary equipment)

Focus

Motorized objective focusing with focus guide box and guide plate for changeable objective holders

- Motorized travel range: 12 mm
- Smallest translation: 0.015 μm
- Max. speed: 5 mm/sec

Guide plate

- Encoded guide plate for three different objective holders and nosepieces with integrated fixture for DIC - objective prism slide possible

Upper part of stand

Consisting of:

Receptacle for analyzer slider

1" motorized fluorescence axis

- Incident-light diaphragm module with motorized FIM (fluorescence intensity manager) and motorized field diaphragm disk
- 5-position encoded and motorized fluorescence cube disk
- Illuminator holder: Leica standard interface for fluorescence lamp housing or 1" light guide couplers (such as the Leica EL6000)

Tube change interface

- For holding the fixed stage tube or Leica standard tubes

2 slide holders for filters or boosters



Fig. 4 Leica DM6000 FS with Leica STP6000



Fig. 5 Leica DM6000 FS, rear view of the stand



Fig. 6 Leica CTR7000 HS



Fig. 7 Leica CTR7000 HS, rear side

Control Boxes and Trigger Boxes

Leica CTR5500 electronics box

For use with a manual or fixed stage.

With built-in power supply 12 V 100 W and control of the automatic microscope functions. Includes USB cable. AC power supply 90–250 V, 50–60 Hz 11 888 820

Leica CTR6000 electronics box

For use with a motorized (rack & pinion) stage.

With built-in power supply 12 V 100 W for controlling the automatic microscope functions. Includes USB cable. AC power supply 90–250 V, 50–60 Hz 11 888 821

Leica CTR6500 electronics box

For use with a motorized (spindle) scanning stage. With built-in power supply 12 V 100 W and for control of the automatic microscope functions. Includes USB cable. AC power supply 90–250 V, 50–60 Hz 11 888 822

Leica CTR6500 HS electronics box

For use with a motorized (spindle) scanning stage.

With built-in power supply for 12 V 100 W and for controlling the automatic microscope functions and built-in sequencer for controlling the simple trigger box (11 640 004). Includes USB cable. AC power supply 90–250 V, 50–60 Hz 11 640 010

Leica CTR7000 HS electronics box (page 6, Fig. 6)

For use with a motorized (spindle) scanning stage.

With built-in power supply for 12 V 100 W and for controlling the automatic microscope functions and built-in sequencer for controlling the multi-trigger box and/or the NiDAQ board (11524007). Includes USB cable. AC power supply 90–250 V, 50–60 Hz 11 640 014

Leica SmartMove (page 7, Fig. 8)

XYZ ergo control panel (without display) for controlling the electronic focus (z) and the motorized stage (xy). With 4 freely programmable function keys. 11 505 180



Fig. 8 Leica SmartMove

Leica STP6000 Smart Touch Panel (page 7, Fig. 9)

XYZ ergo control panel with integrated color-touch screen / display and 11 variable function buttons for controlling every microscope function (focus, stage, DIC, objectives and fluorescence). 11 501 255



Fig. 9 Leica STP6000

Peripheral triggering adapter(page 7, Fig. 10)

A simple trigger box for connecting up to three external devices, such as a camera trigger signal, or system trigger "IN" (as start trigger for a sequence) and system trigger "OUT" (for synchronization). 11 640 004



Fig. 10 Peripheral triggering adapter

BNC box (trigger box) (page 7, Fig. 11)

Trigger for 5 system triggers (2 IN / 3 OUT), trigger for IL or TL shutter, synchronization trigger for NiDAQ box and camera trigger as well 11 640 002



Fig. 11 BNC box (trigger box)

NiDAQ box (page 7, Fig. 12)

Data acquisition box for connecting up to 16 analog data sources with 16-bit resolution and up to 200 Hz sampling frequency 11 524 007



Fig. 12 NiDAQ box

Trigger demo set

For testing and demonstration purposes, a trigger set is offered that can simulate one or more triggers via an external switch. The set consists of two cables and one pushbutton switch. 11 102 279

PC and Software



Fig. 13 Leica DM6000 FS

Leica AF6000 E without monitors

The Leica AF6000 E includes a software license and a PC with mouse and hardware dongle. In addition to comprehensive "On-line Help", the software license covers the following modules: "2D Time-lapse", "Acquisition", "Image Overlay", "Sharpening", "Blurring", "Micron Marker", "Single Line Measurement", and "Change of Contrast, Brightness, Gamma". "Z-stacking" and support for motorized stages are not included in this license. Keyboard and monitor also need to be ordered separately. 11 640 016

For detailed description of the modules and licenses, refer to the AF6000 E product documentation.

Leica AF6000 without monitors

The Leica AF6000 includes all of the components of the AF6000 E. In addition, the Leica AF6000 is designed for fast data acquisition and large data records, and triggering electrophysiological data and images. Other applications include, among others: "Multi-channel" with fast image-overlay, "Z-stacking", "Mark and find", and "Tile-scan". The Leica AF6000 includes a software license, a PC with mouse, and a hardware dongle. Keyboard and monitor need to be ordered separately. 11 640 008

For detailed description of the modules and licenses, refer to the Leica AF6000 E - 7000 product documentation.

Live Data Mode

Leica Application Suite Live Data Mode. Definition of data acquisition in "jobs" and "macros". It is possible to modify the data acquisition during the measurement.

Trigger functions are implemented. 11 640 803

LCD monitor 22" (1680x1050)

The Leica AF6000 E supports either one monitor or two of the same type. 11 600 261

Flat-screen monitor TFT 19"

The Leica AF6000 E supports either one monitor or two of the same type. 11 600 169

USB PC keyboard

French	11 600 219
English (US)	11 600 220
English (UK)	11 600 221
Swedish	11 600 222
Italian	11 600 223
German	11 600 224
Spanish	11 600 225

For cameras, refer to "Digital Image Documentation" in this brochure.

System Designs

Three system designs are available.

- Basic version without sequencer
- System version with sequencer based on CTR6500 HS
- High-end version with sequencer based on CTR7000 HS and data acquisition box

Basic version without sequencer

- Leica DM6000 FS
- Leica CTR5500 for manual stage or
- Leica CTR6000 for motorized stage or
- Leica CTR6500 for scanning stage
- Leica STP6000 control panel
- Leica AF6000 E
- Camera

Fig. 14 Leica DM6000 FS basic version without sequencer

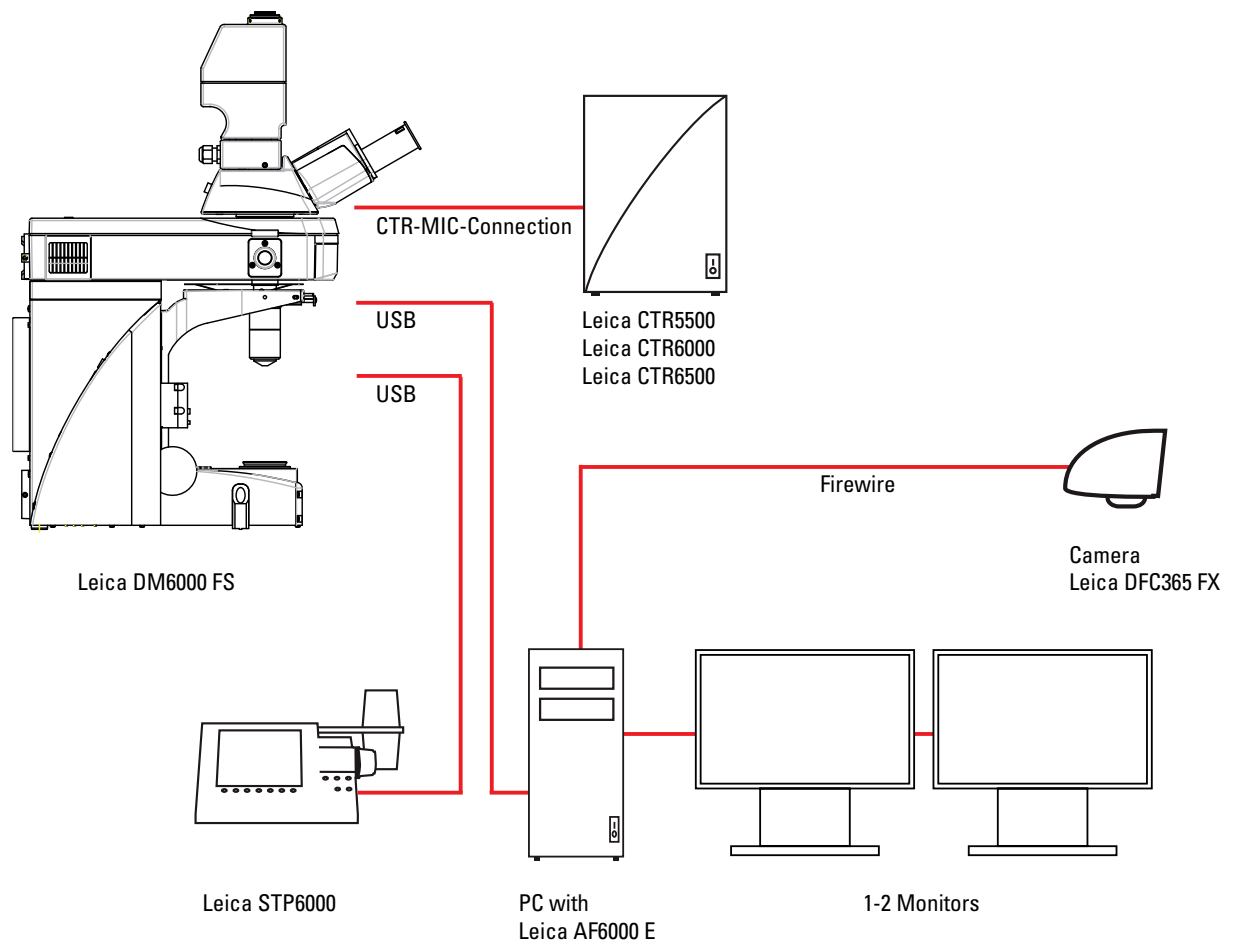

System version with sequencer

based on CTR6500 HS

- Leica DM6000 FS
- Leica CTR6500 HS
- Small trigger box (peripheral triggering adapter)
 - Camera trigger
 - One system trigger IN (e.g. start-trigger for the sequence)
 - One system trigger OUT (e.g. for synchronizing external instruments during sequence start)
- Leica STP6000
- Leica AF6000
- Live Data Mode
- Camera

Fig. 15 Leica DM6000 FS system version with sequencer

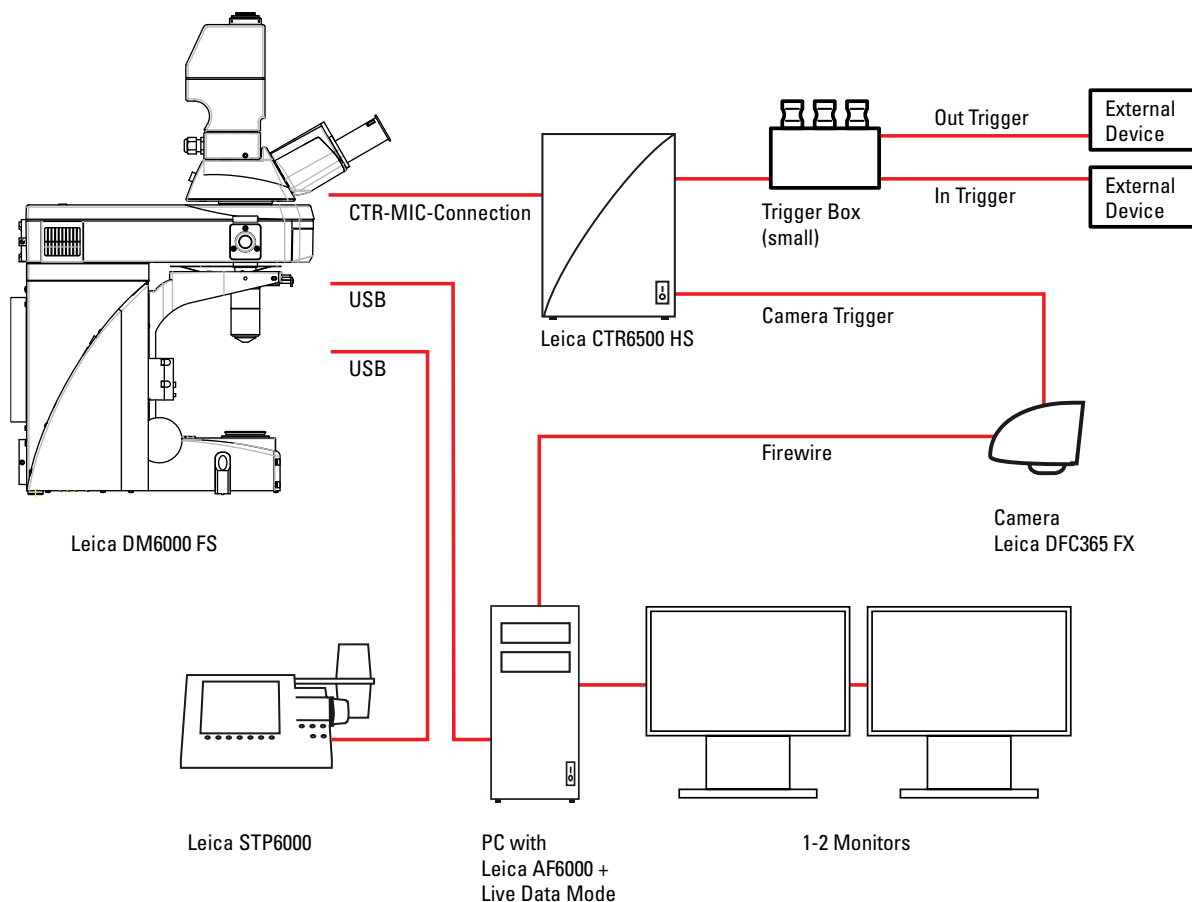

High-end version with sequencer

based on CTR7000 HS and data acquisition box

- Leica DM6000 FS
- Leica CTR7000 HS
- BNC box (trigger box)
 - Camera trigger
 - One system trigger IN (e.g. start-trigger for the sequence)
 - One system trigger OUT (e.g. for synchronizing external instruments during sequence start)
 - Two synchronization triggers for the data acquisition box (start-trigger and synchronization clock for image and data)
- Data acquisition box
 - Up to 16 analog channels via the data acquisition box
- Leica STP6000
- Leica AF6000
- Live Data Mode
- Camera

Fig. 16 Leica DM6000 FS high-end version with sequencer

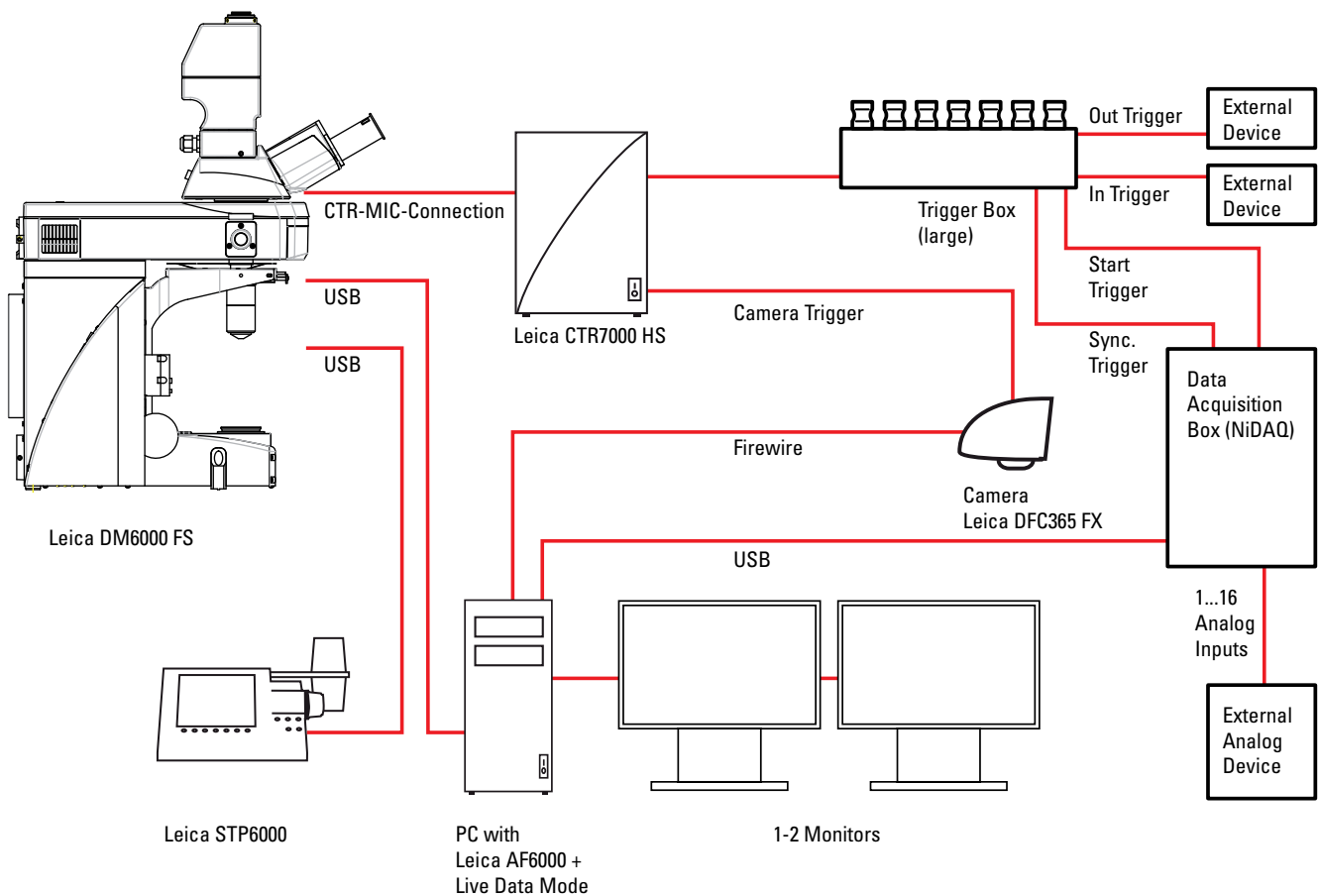

Objective Holders, Objective Changers and Objective Nosepieces

The upper part of stand of the Leica DM6000 FS is equipped with an encoded objective receptacle for three different objective holders, objective changers or objective nosepieces each with an integrated holder for a DIC – objective prism slide.

The objective holders, changers or nosepieces can be switched without tools and are optionally interchangeable. The microscope's electronics identify and activate them.

With encoding, the system recognizes the objective in the beam path and automatically sets the obtained luminous intensity, the aperture and field diaphragm settings, as well as the desired contrast method.

Every objective holder, changer or nosepiece is controlled by the motorized objective focus. As such, the automatic functions made available through the Leica Application Suite (LAS) can be used for all objectives, such as the "DIP-IN" function, which allows the objective to be lowered from the focus position into the fluid medium, and then, after the front lens has been wetted, returned back to focus—all without vibration and without disturbing the experimental setup.

Objective holder for single objective (page 12, Fig. 17)

An encoded individual slide bar for holding a fixed single objective with 75 mm parfocalizing distance and M32 x 0.75 mm objective threading.

Including holder for a DIC objective-prism slider. With the fixed objective, 360° of work surface around the objective are available for microtools. 11 555 089

When using an objective with 45 mm parfocalizing distance and M25 x 0.75 mm objective threading, the parfocal adapter 45/75 is additionally required. 11 505 259



Fig. 17 Objective holder for single objective

Motorized objective changer for 2 objectives

(Page 13, Fig. 18)

An encoded and motorized 2-position objective changer for vibration-free objective changing, for example two water immersion objectives with M25 x 0.75 mm objective threading and 45 mm parfocalizing distance. Changing takes place with precise focusing including liquid wetting; no readjustment is necessary. Including holder for a DIC objective-prism slider. Because none of the objectives swings out toward the side or front, a working area of over 320° is kept free for the use of microtools. To prevent vibration and bubble formation, the objectives are moved in and out of the immersion at an angle and swung away upward and back on an elliptical track, while the second objective carries out the converse motion. 11 524 006



Fig. 18 Motorized objective changer for 2 objectives

Motorized objective nosepiece for up to 6 objectives

(page 13, Fig. 19)

An encoded and motorized 6-position objective nosepiece for vibration-free objective changing, for example multiple water immersion objectives with M25 x 0.75 mm objective threading and 45 mm parfocalizing distance. Including holder for a DIC objective-prism slider. The nosepiece is rotated 90° laterally and is installed at a 22.5° angle to ensure that the objective is swung out almost precisely straight, either towards the front or back. When only three objectives are used, the trajectory of their swinging in and out is practically straight. To prevent vibration and bubble formation, the objectives are moved in and out of the immersion at an angle. 11 501 249



Fig. 19 Motorized objective nosepiece for up to 6 objectives

Tubes, Magnification Changers and TV Adapters

For the Leica DM6000 FS, a motorized trinocular tube that is specially designed for infrared applications is offered with a tube lens system that is adapted to fit the magnification changer for the Leica DM6000 FS. When no magnification changer is being used on the microscope, any manual tube belonging to the Leica DM series can be used.

The tubes are securely attached to the stand cover with positive locking using precise dovetail ring switching and clamping screws. The eyepiece tubes of the tube system are designed based on the Siedentopf principle.

Trinocular Tube DM FS(page 14, Fig. 20)

Motorized, binocular observation tube for fixed stage with photo output for 2 magnification changers and/or one TV adapter, with 2 switch positions for 100% light to the eyepiece or 100% light to the camera output. 11 524 005



Fig. 20 Trinocular Tube DM FS with 3-position magnification changer

3-position magnification changer (page 14, Fig. 20)

For Leica DM6000 FS (0.35x - 1.25x - 4.0x)

Motorized, 3-position magnification changer including C-mount threading for the binocular observation tube for fixed stage with photo output (11 524 005) for use with fixed single objectives (e.g. 25x/ 0.95) with optical magnification levels 0.35x, 1.25x and 4.0 x. 11 524 002

2-position magnification changer

For Leica DM6000 FS (1.25x - 4.0x)

Motorized, 2-position magnification changer including C-mount threading for the binocular observation tube for fixed stage with photo output (11 524 005). For use, for example, with the motorized objective changer for 2 objectives (11 524 006) equipped with a 5x or 10x scanning objective and a working objective, e.g. 25x/0.95 W, with optical magnification levels 1.25x and 4.0 x. 11524003



Fig. 21 Trinocular Tube DM FS with 1-position camera adapter

1-position camera adapter (page 14, Fig. 21)

For Leica DM6000 FS (1.25x)

1-position fixed magnification lens, C-mount threading for the binocular observation tube for fixed stage with photo output (11 524 005). For use, for example, with the motorized objective nose-piece for 6 objectives (11 501 249) equipped with a 5x scanning objective and/or 10x, 20x, 40x, 63x UVI water immersion objectives. 11 524 004

Fixed tubes of the DM series

Tube BT25+ (page 15, Fig. 22)

Binocular observation tube, fixed 30° viewing angle.

11 505 147

Tube BDT25+ (page 15, Fig. 23)

Binocular observation tube with photo port, fixed 30° viewing angle, 3 switch positions: Beam split: 100%:0%, 50%:50%, 0%:100%

11 505 146

Tube BDTP25

Like the BDT25+, but with orientation of the right eyepiece so that the cross-hairs remain aligned in the Pol eyepiece during adjustment of the interpupillary distance.

11 551 076

Photo holder sockets

For 11501249 or tube BDTP25

Mono tube top attachment

Photo/TV holder socket with one output.

11 505 161

Alternatively:

Dual tube top attachment, fixed (50:50)

Photo/TV holder socket with two outputs.

11 505 162

Alternatively:

Dual tube top attachment, selectable (100:100), manual

Photo/TV holder socket with two outputs.

11 505 223

Ergonomic tubes:

Tube AET22 (page 15, Fig. 24)

Binocular ergonomic tube with variable viewing angle 5°–32° and variable eyepiece extension 0–30 mm.

11 505 148

Tube EDT22 (page 15, Fig. 25)

Binocular observation tube with photo port with variable viewing angle 5°–32°. Fixed beam splitting 50%:50%.

11 505 149

Tube with image correction

Tube HC L 2TU 4/5/7 (page 15, Fig. 26)

Binocular observation tube with photo port with image correction,

20° viewing angle, beam split 100%:100%.

11 501 598



Fig. 22 Tube BT25+



Fig. 23 Tube BDT25+



Fig. 24 Tube AET22



Fig. 25 Tube EDT22



Fig. 26 Tube HC L 2TU 4/5/7



Fig. 27 TV adapter

TV adapter (page 16, Fig. 27/28)

You can adapt analog and digital cameras to all tubes with documentation output. The C-B and F-mount adapters are aligned to the dimensions of the holder thread. The various fixed and variable magnification factors allow adjustment of the rendering of the microscopic image on the camera chip. In order to display the largest possible portion of the field of view on the monitor, the magnification factor of the adapter must fit the chip size of the camera. If the magnification is too low, there will be a lack of uniformity to the illuminated area (shading) and/or vignetting.



Fig. 28 Vario TV adapter

	Recorded picture diagonal in mm with				Order No.
	1-inch camera	2/3-inch camera	1/2-inch camera	1/3-inch camera	
Without zoom magnification, for 1-chip cameras only:					
C-mount adapter 1x HC	16	11	8	6	11 541 510
C-mount adapter 0.7x HC	–	15.7	11.4	7.8	11 541 543
C-mount adapter 0.55x HC	–	–	14.5	10.9	11 541 544
C-mount adapter 0.35x HC	–	–	–	17.1	11 541 512
With variable magnification level (Vario TV adapter) for 1–3 chip cameras:					
C-mount 0.32–1.6x HC	–	–	19*–5	18–3.8	11 541 517
Without variable magnification level, for 1-3 chip cameras:					
C-mount adapter 1x	–	–	16	12	11 543 706
B-mount adapter 1x	–	–	16	12	11 543 702
Additionally required for each: TV optics 0.5x HC					11 541 545

* available beginning with Vario factor 0.42 x!

Stages and Specimen Holders

Specimen stages on upright microscopes are attached to a stage bracket. On the Leica DM6000 FS, this stage bracket is located on the condenser holder and is designed for "demonstration stages" and smaller stages only. This is because decoupled stages are used with microscopes designed for electrophysiological applications, meaning the stages are not connected to the microscope directly, but instead are part of a working platform around the microscope. In this case, instead of the specimen being moved, generally the entire microscope, including the optics, is moved over the specimen.

Refer also to: Peripherals for Fixed Stage Applications

Four clamping screws are used to adapt the simple specimen stage. This also allows you to adjust the stage height mechanically independent of the drive movement. On mechanical stages, the x-y stage motion is controlled by a closed cable drive without a rack.

Mechanical stage for Leica DM6000 FS (page 17, Fig. 29)

Cross-stage with ceramic-coated stage plate 188 x 153 mm without rotation, mid-position opening 82 x 30 mm front, adjustment range 76 x 50 mm, right-hand operation with telescoping double connecting rod with separate torque setting for x and y movement. Without slide holder. 11 501 252

Ergonomic slide holder for one specimen

With spring clips for clamping the front side of the specimen, for simultaneous right-handed stage and focus adjustment. Screw fitting on mechanical stage for DM6000 FS. 11 505 163

Plug-in slide holder for 2 specimen slides (page 17, Fig. 30)

For insertion of up to two specimens into a slide adapter. Screw fitting on mechanical stage for DM6000 FS. 11 505 157

Single-hand slide holder for 1 specimen slide (page 17, Fig. 31)

For insertion of one specimen into a slide adapter. Screw fitting on mechanical stage for Leica DM6000 FS. 11 505 156

Motorized cross-stage for Leica DM6000 FS

Motorized cross-stage with step motor with tabletop 234 x 157 mm. Adjustment range 76 x 50 mm. Operation with Leica Smart-Move, Leica STP6000 or Leica software. 11 501250

Single-hand slide holder for 1 specimen (page 17, Fig. 32)

For insertion of one specimen in a slide adapter. Screw fitting on motorized stage for DM6000 FS. 11 505 181

Plug-in slide holder for 2 specimen slides

For insertion of up to two specimens in a slide adapter. Screw fitting on mechanical stage for Leica DM6000 FS. 11 505 182



Fig. 29 Mechanical stage for DM6000 FS

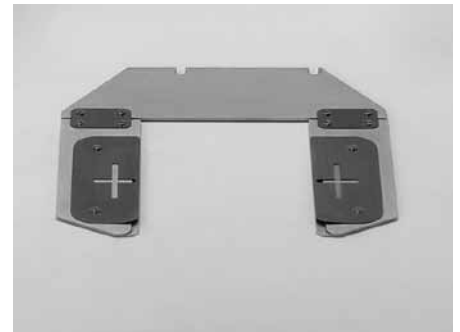

Fig. 30 Plug-in slide holder for 2 specimen slides

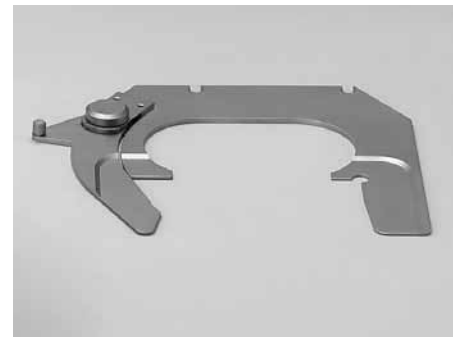

Fig. 31 Single-hand slide holder for 1 specimen slide



Fig. 32 Single-hand slide holder for 1 specimen



Fig. 33 Electrophysiological objectives

Objectives

Based on the Leica principle of infinity distance correction of optics, the microscope objectives are infinity corrected for tube lens systems with 200 mm reference focal lengths. For regular bright field objectives, the parfocalizing distance is 45 mm and the objective threading is M25x0.75 mm. For the fixed stage objective 20x/1.00 W, the optical parfocalizing distance is 75 mm and the objective threading is M32x0.75 mm.

For electrophysiology or patch-clamp applications, Leica offers special objective designs.

UVI water immersion objectives

Very narrow, special objectives for the demands of electrophysiological applications, with high numerical aperture (N.A.), large free working distance (FWD), large access angle (Acc<) and precise, objective-side Wollaston prism, apochromatically corrected with flat front lens and a front area of Marcor and Macrolon.

This eliminates the risk of damage to the optics and achieves a very high objective wettability. The following 4 objectives with 45 mm parfocalizing distance and M25x0.75 mm objective threading available:

Objective	N.A.	FWD	Acc<	DIC	Prism S1/0.9	Order number
HCX APO L 10x / 0.30 W U-V-I	0.30	3.7 mm	> 45°	D1	K2	11 506 142
HCX APO L 20x / 0.50 W U-V-I	0.50	3.6 mm	> 45°	D1	K3	11 506 147
HCX APO L 40x / 0.80 W U-V-I	0.80	3.3 mm	> 45°	D1	K6	11 506 155
HCX APO L 63x / 0.90 W U-V-I	0.90	2.2 mm	> 43°	D1	K7	11 506 148



Fig. 34 Objective HCX IRAPO L 25x/0.95 W

High-aperture infrared-optimized 25x electrophysiology objective (page 18, Fig. 34)

Compact, special objective for the demands of electrophysiology applications. With optimized correction in the near infrared range (up to 900 nm), with high numerical aperture (N.A.), large free working distance (FWD), large access angle (Acc<). Apochromatically corrected with flat front lens and a front area of Marcor and Macrolon. This eliminates the risk of damage to the optics and achieves a very high objective wettability. The parfocalizing distance is 45 mm and the objective threading is M25x0.75 mm.

Objective	N.A.	FWD	Acc<	DIC	Prism S1/0.9	Order number
HCX IRAPO L 25x/0.95 W	0.95	2.5 mm	> 41°	H2	K5	11 506 323

! When using this objective with the objective holder for single objective (11 555 089), the parfocal adapter 45/75 (11 505 259) is additionally required.

With the 3-position magnification changer (0.35x - 1.25x - 4.0x) 11 524 002, the following specifications, among others, result for the objective.

Magnification changer	N.A.	Field of view in mm	Resolution in μm	Depth of focus in μm	Equivalent objective*
0.35	0.25	1.28	1.10	11.6	12.5x/0.25
1.25	0.95	0.36	0.29	0.81	40x/0.95
4.00	0.95	0.11	0.29	0.81	150x/0.95

High-aperture confocal-optimized 20x electrophysiology objective (page 19, Fig. 35)

Compact special objective for the demands of electrophysiology applications, optimized for confocal and 2-photon applications, with high numerical aperture (N.A.), large free working distance (FWD), large access angle (Acc<). Apochromatically corrected with flat front lens and a front area of Marcor and Macrolon. This eliminates the risk of damage to the optics and achieves a very high objective wettability. The parfocalizing distance is 75 mm and the objective threading is M32x0.75 mm.



Fig. 35 Objective HCX APO L 20x/1.0 W

Objective	N.A.	FWD	Acc<	DIC	Prism S1/0.9	Order number
HCX APO L 20x/1.0 W	1.00	2.0 mm	> 39°	H/H2	K7/K16	11 507 701

! The objective holder for single objective 11 555 089 (page 19, Fig. 36) is always required for this objective.

With the 3-position magnification changer (0.35x - 1.25x - 4.0x) 11 524 002, the following specifications, among others, result for the objective.

Magnification changer	N.A.	Field of view in mm	Resolution in μm	Depth of focus in μm	Equivalent objective*
0.35	0.25	1.60	1.10	11.6	10x/0.25
1.25	1.00	0.45	0.27	0.73	32x/1.0
4.00	1.00	0.15	0.27	0.73	110x/1.0

For a detailed objective list, refer to <http://www.leica-microsystems.com/objectives>

There you can also find all other bright field objectives of the various objective classes. Even earlier-type objectives can be adapted for further use. There is an adapter for objectives with RMS thread. When selecting the objectives, consider the intended use with regard to specimen covering, etc. For additional information on using objectives with various condenser heads and/or various contrast methods, refer also to the chapter on Contrast Methods in this brochure.



Fig. 36 Single objective holder

*) Equivalent objective: (11.2 mm camera chip / field of view) / 0.7 C-mount

Eyepieces and Graticules

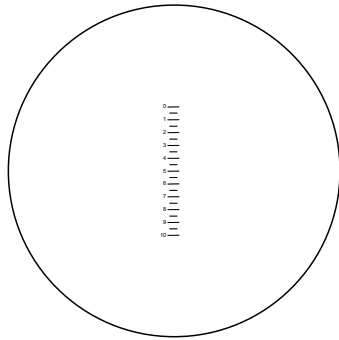

Fig. 37 Graticule 11 506 950

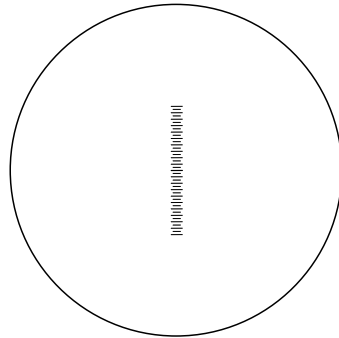

Fig. 38 Graticule 11 506 951

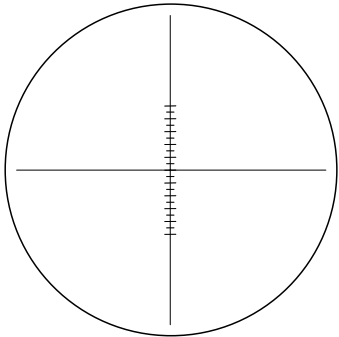

Fig. 39 Graticule 11 506 952

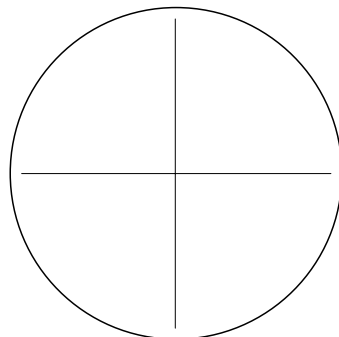

Fig. 40 Graticule 11 506 953

Eyepieces for tube eyepiece

All eyepieces have removable or fold-down eyecups and can be used with or without eyeglasses. Oculars identified with M are equipped with a focusing eyelens for dioptric equalization (from -6.8 to +4.2 or -6 to +5) and graticule holder.

The outer diameter of the eyepiece is $D = 30$ mm. Graticule diameter $D = 26$ mm. The eyepiece data are engraved, e.g. HC PLAN 10x/20 \mathcal{G} M.

HC PLAN = correction type, 10x = magnification/20 = field number FOV, \mathcal{G} = glasses type (high exit pupil), M = dioptric adjustment/graticule holder.

Eyepieces with FOV 20

- Eyepiece HC PLAN 10x/20 BR. 11 507 801
- Eyepiece HC PLAN 10x/20 BR.M 11 507 802

Eyepiece with FOV 22

- Eyepiece HC PLAN S 10x/22 BR.M 11 507 807

Eyepiece with FOV 25 (Fig. 118 p. 45)

- Eyepiece HC PLAN S 10x/25 BR.M 11 507 808

Special eyepieces with high magnification

- Eyepiece HC PLAN 12.5x/16 BR.M 11 506 515
- Eyepiece 16x/14B, adjustable 10 445 301
- Eyepiece 25x/9.5B, adjustable 10 445 302
- Spacer ring for eyepiece 16x/14B and eyepiece 25x/9.5B 11 506 808

Graticules for length measurements, comparison and counting methods

For HC PLAN eyepieces

- Graticule 10 mm = 100 divisions, $D = 26$ mm 11 506 950
- Graticule 10 mm = 200 divisions, $D = 26$ mm 11 506 951
- Crosshair graticule, $D = 26$ mm 11 506 953
- Crosshair graticule with graduation, 10 mm = 100 divisions, $D = 26$ mm 11 506 952
- Crosshair graticule with grid 10 x 10 mm, 0.1 mm graduation, $D = 26$ mm 11 506 954
- Crosshair graticule with grid 10 x 10 mm, 1 mm graduation, $D = 26$ mm 11 506 955

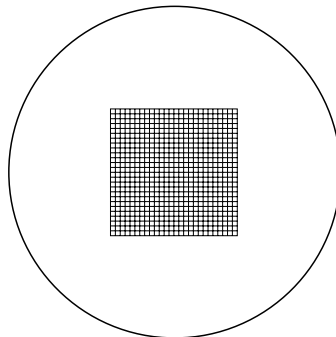

Fig. 41 Graticule 11 506 954

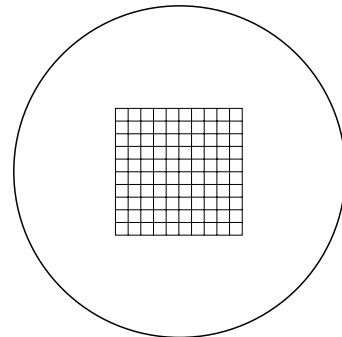

Fig. 42 Graticule 11 506 955

Transmitted-Light Contrast

Method, Condensers

The transmitted-light illumination system is based on a commercially available 12 V, 100 W halogen bulb, the luminous intensity of which is automatically adjusted to the preset value based on the density of the specimen and the light stream in the objective. The adjustment is color-neutral, i.e. the color temperature remains constant. Refer to the corresponding chapters in this brochure for information on the various light sources, lamp housing and corresponding power supplies.

The different transmitted-light methods generally require different condensers and/or condenser heads.

The Leica DM6000 FS uses a condenser that is specially designed for applications in electrophysiology. Here it is important that the seal between the condenser head and the housing is watertight and that liquid is led away in the event of a "water accident".

Bright field, phase contrast, dark field, polarization-contrast and differential interference contrast

The encoded objective nosepiece recognizes the objective currently being used, and automatically adjusts the luminous intensity and field diaphragm to preset values. The user can adjust and overwrite the preset values at any time.

Required components:

Leica DM6000 FS Condenser (page 21, Fig. 43)

Centerable condenser for Koehler illumination for objectives with magnifications 10x–100x for bright field, phase contrast, polarization contrast and differential interference contrast.

Complete with: 11 505 245

- Manual condenser holder for attaching to the stand column and a positioning range of 28 mm and a manual stop for the optimum "Koehler" position.
- Sub-condenser with 4 receptacles for prisms or light rings and one receptacle for the condenser head, with manual aperture diaphragm and manual centering for the illuminated field diaphragm (without prisms or condenser head)
- Polarizer holder (without polarizer)

Condenser head 0.90 S1 (page 21, Fig. 44)

Focal intercept 1 mm, low strain for all transmitted-light contrast methods. 11 505 150

Condenser head P 0.90 S1 (page 21, Fig. 44)

Focal intercept 1 mm, extremely low strain for all transmitted-light contrast methods. 11 551 072

Condenser head P 1.40 OIL S1, achromatic (page 21, Fig. 44)

Focal intercept 1 mm, extremely low strain, for highest microscopic resolution or for use with Dodt contrast. 11 551 004



Fig. 43 Leica DM6000 FS Condenser



Fig. 44 Condenser heads



Fig. 45 Light rings



Fig. 46 Focusing telescope

Bright field

For bright field applications, no additional inserts are necessary in the condenser. Contrasting is regulated completely by the aperture and illuminated field diaphragm.

Phase contrast and dark field

The Leica DM6000 FS, like all microscopes of the DM series, can also be equipped for dark field and phase contrast. This requires no more than installing the corresponding light rings or dark field stop in the condenser. These contrast methods, however, are not placed in the foreground when it comes to electrophysiology applications. Dark field is possible with a maximum objective aperture of 0.7.

The light rings (page 22, Fig. 45) and the dark field stop, in a 32 mm version, must be inserted into the condenser disk. The following light rings are available on request:

Light ring 1 for PH1 phase objectives	11 023 121 050 008
Light ring 2 for PH2 phase objectives	11 023 123 052 005
Light ring 3 for PH3 phase objectives	11 090 132 050 020
Dark field stop	11 090 132 050 026

Focusing telescope (page 22, Fig. 46)

For equal coverage adjustment of light and phase ring, and control of the compensation strip for interference contrast.

11 505 070

Transmitted-light–polarization contrast

The Leica DM6000 FS, like all microscopes of the DM series, can also be equipped for simple polarization contrast. This requires no more than bringing a polarizer and an analyzer into the beam path. These two components are also required for differential interference contrast. For transmitted-light polarization contrast, a rotating polarizer and an analyzer (fixed or rotating) are required. Low-strain objectives and condenser lenses increase the quality of the polarization contrast.

Polarizer in holder (page 23, Fig. 47)

The polarizer holder is located below the Leica DM6000 FS Condenser and is attached with a knurled screw. This holder can be swung in and out. The inserted polarizer can be rotated in the holder.

Infrared polarizer in holder $\varnothing = 32$ mm 11 555 064

Alternative (not infrared-optimized):

Polarizer in holder $\varnothing = 32$ mm

- Without heat-absorbing filter 11 505 087
- With heat-absorbing filter 11 513 711

For other "Filters in holder $\varnothing = 32$ mm" for the condenser holder, refer to the chapter on Transmitted-Light Filters in this brochure.

Analyzer on slider

The following analyzers can be inserted into the analyzer holder slot below the tube once the dust cover insert has been removed.

Infrared analyzer ICT/P (page 23, Fig. 48.1)

In slide bar 126 x 30 x 5 mm, fixed orientation 90° (north-south), and with an empty position. 11 555 090

Alternative (not infrared-optimized):

Analyzer ICT/P (page 23, Fig. 48.2)

In slide bar 126 x 30 x 5 mm, fixed orientation 90° (north-south) and with an empty position. 11 555 045

Analyzer IC/P, 180° (page 23, Fig. 49)

In slide bar 126 x 30 x 5 mm, rotating from 0°–180° with drum head graduation, 1 scale interval = 5°. 11 555 079

Analyzer 360° (page 23, Fig. 50)

In slide bar 126 x 30 x 5 mm, rotating, with vernier 0.1° 11 555 080

Analyzer block (page 23, Fig. 51)

The analyzer block can be installed with stands having incident-light fluorescence axis, and can be swung into the beam path using a motorized reflector disk. The swing direction is fixed at 0° (east-west). 11 513 900



Fig. 47 Polarizer in holder $\varnothing = 32$ mm



Fig. 48 Infrared analyzer (1) and analyzer ICT/P (2)



Fig. 49 Analyzer IC/P, 180°



Fig. 50 Analyzer 360°



Fig. 51 Analyzer block

Transmitted-light interference contrast

The Leica DM6000 FS, like all microscopes of the DM series, can also be equipped for differential interference contrast. This requires no more than bringing a polarizer and an analyzer and a Wollaston prism pair (condenser prism: Kx and objective prism: A - H) into the beam path. For transmitted-light interference contrast, a rotating polarizer and an analyzer (fixed or rotating) are required. Low-strain objectives and condenser lenses increase the quality of the differential interference contrast.

For suitable polarizers and analyzers, refer to
Transmitted-light polarization contrast

ICT condenser prisms (page 24, Fig. 52)

The following condenser prisms are available for installation in the 4-position condenser disk of the Leica DM6000 FS Condenser 11 505 245. Which prisms are needed depends on the condenser head and objective being used. Refer also to the objective list: <http://www.leica-microsystems.com/objectives>

- ICT condenser prism K1A 11 555 057
- ICT condenser prism K1B 11 555 070
- ICT condenser prism K2 11 555 016
- ICT condenser prism K3 11 555 017
- ICT condenser prism K4 11 555 018
- ICT condenser prism K5 11 555 019
- ICT condenser prism K6 11 521 521
- ICT condenser prism K7 11 521 522
- ICT condenser prism K8 11 521 523
- ICT condenser prism K9 11 555 030
- ICT condenser prism K10 11 521 524
- ICT condenser prism K11 11 521 529
- ICT condenser prism K12 11 521 540
- ICT condenser prism K15 11 555 060
- ICT condenser prism K16 11 522 037
- ICT condenser prism K17 11 555 091

ICT/ICR objective prisms

Depending on the objective receptacle in use (objective holder, objective changer or objective nosepiece), various objective prisms are available. Which prisms are needed depends on the objective being used. Refer also to the objective list: <http://www.leica-microsystems.com/objectives>

For the Leica DM6000 FS, the objective prism holder is part of the objective receptacle, and objective prisms on sliders are required:



Fig. 52 Condenser prisms

For the motorized objective nosepieces for max. 6 objectives 11 501 249, the following prisms are available in sliders:

- IC prism A 11 555 036
- IC prism B1 11 555 038
- IC prism C 11 555 039
- IC prism D (wide splitting, high contrast) 11 555 037
- IC prism D1 (narrow splitting, high resolution) 11 555 063
- IC prism E in slider 11 555 072



Fig. 53 IC prism D1

In electrophysiology, the following objectives are predominantly used with the motorized 6-position objective nosepiece.

Objective	Objective prism	Splitting at 750 nm	Condenser prism S1/0.9	Condenser prism S1/1.4 oil
10x /0.30 W APO UVI	D1	1.17 μm	K2	–
20x /0.50 W APO UVI	D1	0.58 μm	K3	–
40x /0.50 W API UVI	D1	0.29 μm	K6	–
63x /0.50 W APO UVI	D1	0.18 μm	K7	K17
25x /0.95 W IRAPO	D1	0.47 μm	K16	–

For the objective holder for single objective 11 555 089 and the motorized objective changer for 2 objectives 11 524 006, the following prisms are available in sliders:

- IC prism H (for confocal microscopes) 11 555 088
- IC prism H2 11 555 092



Fig. 54 IC prisms H and H2

In electrophysiology, the following objectives are predominantly used with the motorized 2-position objective changer.

Objective	Objective prism	Splitting at 750 nm	Condenser prism S1/0.9	Condenser prism S1/1.4 oil
10x /0.30 W APO UVI	H2	0.90 μm	–	–
20x /0.50 W APO UVI	H2	0.45 μm	K16	–
40x /0.50 W API UVI	H2	0.23 μm	K4	K9
63x /0.50 W APO UVI	H2	0.14 μm	K8	K17
25x /0.95 W IRAPO	H2	0.36 μm	K5	K15

In electrophysiology, the following objectives are predominantly used with the encoded fixed objective holder.

Objective	Objective prism	Splitting at 750 nm	Condenser prism S1/0.9	Condenser prism S1/1.4 oil
20x /1.00 W APO	H (confocal)	0.18 μm	K7	K17
20x /1.00 W APO	H2	0.45 μm	K16	–
Use each of the following objectives with parfocal adapter 45/75 (11 505 269)				
25x /0.95 W IRAPO	H2	0.36 μm	K5	K15
10x /0.30 W APO UVI	H2	0.90 μm	–	–
20x /0.50 W APO UVI	H2	0.45 μm	K16	–
40x /0.50 W API UVI	H2	0.23 μm	K4	K9
63x /0.50 W APO UVI	H2	0.14 μm	K8	K17



Fig. 55 Filter holder (part of the condenser)



Fig. 56 Transmitted-light filter

Transmitted-light filter (page 26, Fig. 56)

For insertion into the polarizer holder on the condenser or for loose attachment to the transmitted-light opening in the stand base. The following filters are offered with holder and diameter $\varnothing = 32$ mm

- **DLF, daylight filter** (blue, conversion filter for daylight film and visual observation) 11 514 753
- **ALF, artificial light filter** (red, correction filter for artificial light film) 11 514 754
- **Panchromatic green filter** for B/W photography 11 512 077
- **VG 9, green filter** for contrast enhancement (B/W) 11 563 122
- **IL 546 nm** (polarization microscopy, interferometry) 11 563 155
- **Neutral filter N 2** (50%), in holder 11 543 092
- **Neutral filter N 4** (25%) 11 543 093
- **Neutral filter N 16** (6.3%) 11 543 184
- **Neutral filter N 16** (6.3% oblique) 11 514 752
- **Polarizer** 11 505 087
- **Lambda plate** 11 513 908
- **Quarter lambda plate** 11 513 570
- **Polarizer with protective filter** 11 513 711

Alternatively:

Filter holder

For two filters with $D = 32$ mm in holder, fastened using knurled screw underneath the condenser. 11 505 085

Incident-Light Fluorescence, Filter Cube

Every Leica DM6000 FS comes equipped with an integrated motorized incident-light fluorescence axis. It is part of the upper part of the stand and thus included in the order number of the stand 11 888 928.

The 1-inch fluorescence axis consists of:

- Incident-light diaphragm module with motorized FIM (fluorescence intensity manager) and motorized field diaphragm disk
- 5-position encoded and motorized fluorescence cube disk
- Illuminator holder: Leica standard interface for fluorescence lamp housing or 1" light guide couplers (such as the Leica EL6000)

FIM (Fluorescence Intensity Manager) is a method for decreasing light intensity or an option for equalizing the brightness level. This adjustment can be made in 5 increments.

All incident-light axes are equipped with a motorized light stop, which is activated via the user interface. This shutter prevents bleaching of the specimens.

A switchable, optional auxiliary lens (booster) provides maximum fluorescence brightness.

The incident-light illumination system for fluorescence is based on high-intensity high-pressure mercury burners Hg 100 W with light emission in the short-wave spectral range. Furthermore, xenon lamps XE 75 W are used when a broadband spectrum range is to be covered. In exceptional cases, for specimens with very good fluorescence, the halogen bulb 12 V 100 W is sometimes used.

See: Light Sources, Lamp Housing and Supply Units in this brochure.

The filter systems (blocks) have spring clamps for clicking into the incident-light nosepiece disc. All relevant blocks are equipped with a red absorption filter BG38 for contrast enhancement.

Optional:

Booster lens (page 27, Fig. 57)

Filter slide to increase light intensity in the event of weak fluorescence. 11 888 124

Required:

Fluorescence filter systems (page 27, Fig. 58)

Changing to the fluorescence disk does not require any tools. When changing the filter system (e.g. for multi-wave technique), there is no detectable image shift (zero pixel shift) due to high-precision manufacturing technology.

You can view a current list of the fluorescence cubes at:

<http://www.leica-microsystems.com/filtercubes>



Fig. 57 Booster lens

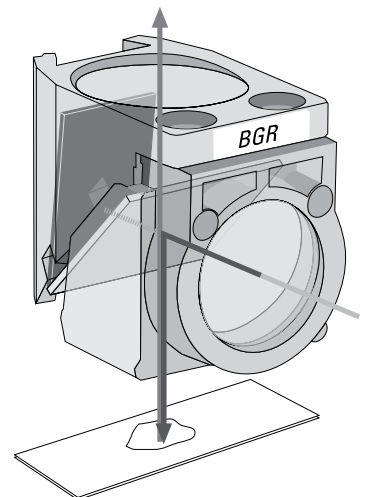

Fig. 58 Fluorescence filter systems

Light Sources, Lamp Housing, Supply Units

The light sources are housed in lamp mounts, which are housed in lamp housings. The lamp housings are fastened to the stand using a flange ring. This allows optimum heat decoupling and comfortable handling. The following equipment is available:

For transmitted-light

The standard lamp housing for the Leica DM6000 FS is not equipped with a built-in heat filter, since that is used specifically for infrared transmitted-light contrast methods. Due to the possible use in a Faraday cage, the lamp housing has an extra-long 3 m cable and is covered with a special shielding.

Lamp housing without heat-absorbing filter

107/2 lamp housing for electrophysiology (page 28, Fig. 59)

(Infrared application)

Without heat-absorbing filter with 3 m screened cable (single-lens) lamp housing made of plastic with lamp access from above. With fixed, pre-centered lamp mount with 3 m screened power cable, including 1x halogen bulb 12 V 100 W. With single-lens aspherical, permanently set collector, without heat-absorbing filter and without reflector. With built-in microprism grid disk with middle diffuser for magnifying the lamp filament and optimizing the illumination. 11 524 008



Fig. 59 Lamp housing 107/2 without heat-absorbing filter

Alternative

Standard lamp housing with heat-absorbing filter

(not suitable for infrared applications or Dodt contrast):

107/2 lamp housing with heat-absorbing filter with 3 m screened cable (single-lens) (page 28, Fig. 60)

Plastic lamp housing with lamp access from above. With fixed, pre-centered lamp mount with 3 m screened power cable, including 1x halogen bulb 12 V 100 W. With single-lens aspherical, permanently set collector, with built-in heat-absorbing filter and without reflector. With built-in microprism grid disk with middle diffuser for magnifying the lamp filament and optimizing the illumination. 11 504 085

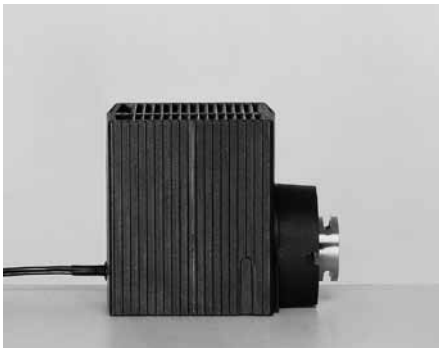

Fig. 60 107/2 lamp housing with heat-absorbing filter

107/2 lamp housing with heat-absorbing filter with 2.5 m cable (single-lens)

Like 11 504 085, but with 2.5 m regular cable. 11 505103

107/2 lamp housing with heat-absorbing filter with 2 m cable (single-lens)

Like 11 504 085, but with 2.5 m regular cable. 11 505 098

Lamp housing 107 (double-lens)

Plastic lamp housing with lamp access from above. With centerable lamp mount with 2.5 m power cable including 1x halogen bulb 12 V 100 W. With double-lens aspherical, focusable collector, with heat-absorbing filter, with microprism grid disk with middle diffuser for magnifying the lamp filament and optimizing the illumination, without reflector. 11 504 101

106 lamp housing (double-lens) (page 29, Fig. 61)

Metal lamp housing with side lamp access. With centerable lamp mount with 2 m power cable including 1x halogen bulb 12 V 100 W. With double-lens aspherical, focusable collector, with heat-absorbing filter, with microprism grid disk with middle diffuser for magnifying the lamp filament and optimizing the illumination, without reflector. 11 504 059

Dot gradient contrast (DGC)

For optimum contrast and improved resolution, DGC is offered for thick brain sections: A patented segment illuminator by and according to Prof. U. Dodt. As an alternative to infrared DIC and likewise combinable with fluorescence. DGC is integrated between the stand and lamp housing into the transmitted-light illumination beam and is available as a manual or motorized variant. For optimum contrast, use a condenser head with the greatest possible aperture (e.g. condenser head S1/1.4 oil 11 551 004).

Manual Dodt contrast 11 531 924

Motorized Dodt contrast 11 531 925

Control system for motorized Dodt contrast 11 531 926

For fluorescence:

The standard fluorescence illuminator for the Leica DM6000 FS is the fiber optic coupling Leica EL6000.

Leica EL6000 (page 29, Fig. 62)

External, alignment-free light source with metal halide lamp 120 W with average service life of over 2000 hours. With removable heat-absorbing filter, running-time meter, manual attenuator and ultra-high-speed shutter. 11 504 115

Light guide (page 29, Fig. 63.1)

Gel-filled, elastic light guide for connecting the EL6000 and microscope via the 2 mm -> 5 mm diameter adapter. 11 504 116

Adapter 1" (page 29, Fig. 63.2)

Adapting light guide microscopes with 1" fluorescence axis. Optimizing the illumination. 11 504 117

Cable for shutter

The fluorescence stop can be controlled via the I²C interface on the Leica DM6000 FS. 11 500 331



Fig. 61 Lamp housing 106/2



Fig. 62 Lamp housing 106/2



Fig. 63 Light guide (1) and 1" adapter (2)



Fig. 64 Lamp housing 106Z – Hg 100 W,

106Z lamp housing – Hg 100 W, 1" (6-lens) (page 30, Fig. 64)

Metal lamp housing with side lamp access. With centerable lamp mount for Hg 100 W lamp with 1.5 m long power cable. 6-lens, achromatic collector, UV-optimized transmission > 50% at 340 nm, centerable reflector for doubling the focal point and optimization of the illuminated area, with heat-absorbing filter, without burner. 11 504 114

Lamp housing 106Z – Hg 100 W, 1" (6-lens)

Like 11 504 114, but with left-hand operation (in the direction of the illumination beam). 11 504 114

Lamp housing 106Z – Xe 75 W, 1" (6-lens)

Metal lamp housing with side lamp access. With centerable lamp mount for Xe 75 W lamp with 1.5 m long power cable. 6-lens, achromatic collector, UV-optimized transmission > 50% at 340 nm, centerable reflector for doubling the focal point and optimization of the illuminated area, with heat-absorbing filter, face protection, protective gloves, without burner. 11 504 105

Lamps and burners

- Halogen bulb 12 V 100 W 11 500 974
- High-pressure mercury burner Hg 50 W 11 500 137
- High-pressure mercury burner Hg 100 W/2 11 500 321
- High-pressure xenon lamp Xe 75 W 11 500 139
- HXP-R120W/45C VIS for Leica EL6000 11 504 120

Light filters and adapters

Spacer for filter Ø = 50 mm (page 30, Fig. 65)

2 filter slots with LH 106/107,
 4 filter slots with LH 106 Z.
 Adapter between lamp housing and microscope. 11 504 030

Filter in holder for Xe 75 W lamp:

Gray filter 0.2%
 D = 50 mm, 0.2% transparency, in holder. 11 514 031

Diffusion filter N
 D = 50 mm, embossed, in holder 11 514 042

Additional filters D = 50 mm in holder:

- DLF, daylight filter 11 514 755
- ALF, artificial light filter 11 514 756
- Panchromatic green filter 11 542 131
- VG 9, green filter 11 514 041
- Neutral gray filter N20 (5%) 11 514 036
- Heat-absorbing filter 11 514 027

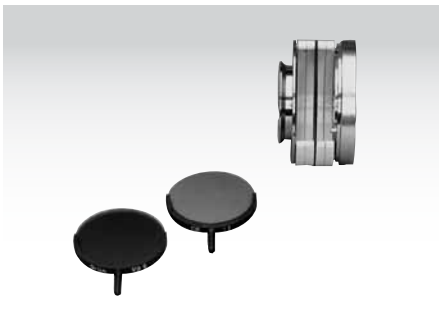

Fig. 65 Adapter for filter Ø = 50 mm

Supply units

Supply unit Hg 50 W (only for 220–240 V) (page 31, Fig. 66)

With power supply cord 11 500 277

For power supply voltages other than 220–240 V, the following is required:

Pre-transformer 100–120 V

With power supply cord, primary 100–120 V, secondary 220–230 V.
11 500 316

Supply unit Hg 100 W (page 31, Fig. 67)

With power supply cord, automatic switching to power supply voltage 90 V–250 V 50/60 Hz with operating hours display
11 500 325

Supply unit Xe 75 W (not pictured)

With power supply cord, automatic switching to power supply voltage 90 V–250 V 50/60 Hz with operating hours display
11 500 324

Transformer for 12 V 100 W (not pictured)

For simultaneous incident-light and transmitted illumination 11 501 179



Fig. 66 Supply unit Hg 50 W



Fig. 67 Supply unit Hg 100 W

Digital Image Documentation

Leica Digital Camera System DFC (page 31, Fig. 68)

Monochrome and color digital cameras for all requirements between highest resolution and quick live image. Some cameras are specially designed for infrared and patch-clamp applications (refer to the technical data sheets for the cameras).

All the cameras listed below are integrated into the LAS AF:

Cameras

Leica DFC310 FX	color CCD	11 547 002
Leica DFC345 FX	monochrome CCD	11 547 003
Leica DFC365 FX	monochrome CCD	11 547 004
Leica DFC425 C	color CCD	12 730 222
Leica DFC495	color CCD	12 730 471
Roper CoolSnap HQ2	monochrome CCD	11 532 576
Roper Cascade II 512	EM CCD	11 600 259
Hamamatsu Orca R ²	monochrome CCD	11 600 266
Hamamatsu 9100-02	EM CCD Camera High Speed	11 640 270
Hamamatsu 9100-13	EM CCD Camera High Speed	11 600 239
Andor iXon DU-897	EM CCD Camera	11 600 240
Andor iXon DU-885	EM CCD Camera	11 600 251

FireWire cable DFC

Some of the cameras listed above require a 9-pin, 3-meter long FireWire IEEE 1394b cable
11 600 269



Fig. 68 Leica DFC310 FX

Additional accessories

Immersion oil, 10 ml

As per ISO 8036/1, refraction index $n_e^{23} = 1.5180 \pm 0.005$,
dispersion $v_e^{23} = 44 \pm 2$ 11 513 859

Immersion oil, 20 ml

As per ISO 8036/1, refraction index $n_e^{23} = 1.5180 \pm 0.005$,
dispersion $v_e^{23} = 44 \pm 2$ 11 513 860

Immersion oil, 250 ml

Free of natural fluorescence as per ISO 8036/1, refractive index
 $n_e^{23} = 1.5180 \pm 0.005$, dispersion $v_e^{23} = 44 \pm 2$ 11 513 861

Screw cap

For empty objective positions on the objective nosepiece
11 020-422-580-028

Manual trigger demo kit

Cables and triggers for sending a trigger signal to the control unit
11 102 279

Peripherals for Fixed Stage Applications

The design of a microscopy workstation for electrophysiology includes substantially more than a microscope and a camera system. The Leica DM6000 FS is compatible with most peripheral instruments used in neuroscience. The design of a patch-clamp station, for example, frequently depends on the question investigated by the experiment or on advantages of a particular manufacturer. In the following list of primarily used peripherals, some of the major manufacturers are named. The list is not exhaustive. You can find more details on the offered NeuroScience products at the websites. In special cases, products from these suppliers are also available through a Leica order number. For information on this, look in the product database in the Leica Intranet or contact product management in Wetzlar, Germany.

Patch-clamp stages

Luigs & Neumann: <http://www.luigs-neumann.com/> > Patchclamp
Exfo-Burleigh: <http://www.exfo-burleigh.com/products-gibraltar.php>
Siskiyou: <http://www.siskiyou.com/platform-applications-examples-index.shtml>

Micromanipulation

Luigs & Neumann: <http://www.luigs-neumann.com/> > Components
Exfo-Burleigh: <http://www.exfo-burleigh.com/products-manipulators.php>
Narishige: <http://products.narishige-group.com/group1/electro/english.html>
HEKA: <http://www.heka.com> > Electrophysiology > Instruments
Sutter: <http://www.sutter.com/products/micromanipulation.html>
Eppendorf: <http://www.eppendorf.com/int/index.php?l=1> > Products > Overview >
Siskiyou: <http://www.siskiyou.com/micromanipulator-index.shtml>
Newport: <http://www.newport.com/Micromanipulators/845437/1033/catalog.aspx>

X-Y translation stages

Luigs & Neumann: <http://www.luigs-neumann.com/> > Patchclamp
Exfo-Burleigh: <http://www.exfo-burleigh.com/products-mounts.php>
Sutter: http://www.sutter.com/products/product_sheets/MT-1000.html
Siskiyou: <http://www.siskiyou.com/microscope-translators-advanced.shtml>
Prior: http://www.prioruk.com/productinfo_auto_motorised_proscan.html

Antivibration

TMC: <http://www.techmfg.com/portals/lifescience.html>
Newport: <http://www.newport.com/Optical-Tables-and-Vibration-Control/137658/1033/catalog.aspx>

Faraday cages

HEKA: <http://www.heka.com> > Electrophysiology > Instruments
TMC: <http://www.techmfg.com/portals/magnetics.html>
Newport: <http://www.newport.com/Faraday-Cage/846936/1033/catalog.aspx>

Electronics, amplifiers

HEKA: <http://www.heka.com> > Electrophysiology > Instruments
Axon: http://www.moleculardevices.com/pages/instruments/electrophys_main.html

Notes

“With the user, for the user”

Leica Microsystems

Leica Microsystems operates globally in four divisions, where we rank with the market leaders.

● Life Science Division

The Leica Microsystems Life Science Division supports the imaging needs of the scientific community with advanced innovation and technical expertise for the visualization, measurement, and analysis of microstructures. Our strong focus on understanding scientific applications puts Leica Microsystems' customers at the leading edge of science.

● Industry Division

The Leica Microsystems Industry Division's focus is to support customers' pursuit of the highest quality end result. Leica Microsystems provide the best and most innovative imaging systems to see, measure, and analyze the microstructures in routine and research industrial applications, materials science, quality control, forensic science investigation, and educational applications.

● Biosystems Division

The Leica Microsystems Biosystems Division brings histopathology labs and researchers the highest-quality, most comprehensive product range. From patient to pathologist, the range includes the ideal product for each histology step and high-productivity workflow solutions for the entire lab. With complete histology systems featuring innovative automation and Novocastra™ reagents, Leica Microsystems creates better patient care through rapid turnaround, diagnostic confidence, and close customer collaboration.

● Surgical Division

The Leica Microsystems Surgical Division's focus is to partner with and support surgeons and their care of patients with the highest-quality, most innovative surgical microscope technology today and into the future.

The statement by Ernst Leitz in 1907, “with the user, for the user,” describes the fruitful collaboration with end users and driving force of innovation at Leica Microsystems. We have developed five brand values to live up to this tradition: Pioneering, High-end Quality, Team Spirit, Dedication to Science, and Continuous Improvement. For us, living up to these values means: **Living up to Life.**

Active worldwide

Australia:	North Ryde	Tel. +61 2 8870 3500	Fax +61 2 9878 1055
Austria:	Vienna	Tel. +43 1 486 80 50 0	Fax +43 1 486 80 50 30
Belgium:	Groot Bijgaarden	Tel. +32 2 790 98 50	Fax +32 2 790 98 68
Canada:	Richmond Hill/Ontario	Tel. +1 905 762 2000	Fax +1 905 762 8937
Denmark:	Herlev	Tel. +45 4454 0101	Fax +45 4454 0111
France:	Nanterre Cedex	Tel. +33 811 000 664	Fax +33 1 56 05 23 23
Germany:	Wetzlar	Tel. +49 64 41 29 40 00	Fax +49 64 41 29 41 55
Italy:	Milan	Tel. +39 02 574 861	Fax +39 02 574 03392
Japan:	Tokyo	Tel. +81 3 5421 2800	Fax +81 3 5421 2896
Korea:	Seoul	Tel. +82 2 514 65 43	Fax +82 2 514 65 48
Netherlands:	Rijswijk	Tel. +31 70 4132 100	Fax +31 70 4132 109
People's Rep. of China:	Hong Kong	Tel. +852 2564 6699	Fax +852 2564 4163
Portugal:	Lisbon	Tel. +351 21 388 9112	Fax +351 21 385 4668
Singapore		Tel. +65 6779 7823	Fax +65 6773 0628
Spain:	Barcelona	Tel. +34 93 494 95 30	Fax +34 93 494 95 32
Sweden:	Kista	Tel. +46 8 625 45 45	Fax +46 8 625 45 10
Switzerland:	Heerbrugg	Tel. +41 71 726 34 34	Fax +41 71 726 34 44
United Kingdom:	Milton Keynes	Tel. +44 1908 246 246	Fax +44 1908 609 992
USA:	Bannockburn/Illinois	Tel. +1 847 405 0123	Fax +1 847 405 0164

and representatives in more than 100 countries