

HighLight FAP System

Sub-kW Direct-Diode Laser System

The HighLight FAP System delivers up to 100W of CW diode light with a modular fiber delivery system. Utilizing Coherent's proprietary in-house epitaxy and laser bar packaging technology, these turnkey systems are ideally suited for industrial applications that require reliable 24/7 operation under harsh conditions.

The system is engineered to deliver exceptional reliability, convenience and superior process uniformity for demanding, high throughput industrial applications such as FRIT welding of OLED displays and other thermal processing tasks like soldering, plastics welding, and remote heating.

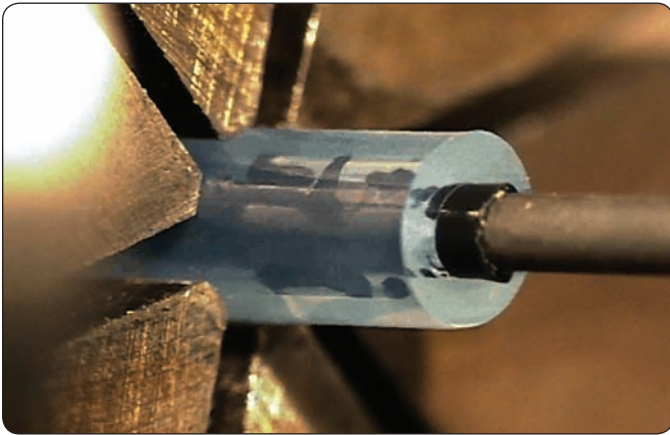

Superior Reliability & Performance

HighLight FAP System Features:

- **Output powers of 30W, 60W and 100W at 810 nm wavelength**
- **Air-cooled**
- **Alignment laser**
- **Adjustable back reflection sensor**
- **19" rack mountable**
- **Excellent power stability**
- **Graphical user interface**
- **Serial and/or analog/TTL control**
- **Reliable and robust**
- **Accessories:**
 - Industrial delivery fiber with 800 μm fiber core with round or square option
 - Variable aberration corrected imager with 1.2x to 1.5x magnification for Top Hat profiles with sharp edges

HighLight FAP System Applications:

- **Plastic Welding**
- **Frit Welding**
- **Soldering**
- **Localized Heating**
- **Remote Heating**

www.Coherent.com/HighLightFAPSystem

HighLight FAP System

Sub-kW Direct-Diode Laser System

System Specifications

	HL-FAP 30	HL-FAP 60	HL-FAP 100
Output Power (W)	30	60	100
Wavelength (nm)		800 to 820	
Power Stability 6σ (%)		± 2	
Rise Time at 60W (μ s)		<50	
Numerical Aperture at Fiber Port	<0.15	<0.15	<0.17
Beam Diameter at Fiber Port (μ m)		800	
Connector at Fiber Port		SMA 905	
Internal Control		RS-232/GUI	
Analog Control (V)		0 to 5	
Gating		TTL	
Interlocks/Emergency Stop		Yes	
Operating Voltage (VAC)		100 to 220 auto-scaling	
Operating Frequency (Hz)		50 or 60	
Max. Current Draw (A)	8	10	15
Weight	~16 kg (36 lbs.)	~18 kg (40 lbs.)	~20 kg (44 lbs.)
Dimensions (W x H x D)		~482 x 191 x 497 mm (19 x 7.5 x 20 in.)	
Operating Temperature		15 to 35°C (°F)	
Operating Humidity (Rel. %)		<90%, non-condensing	
Storage Temperature		-20 to 50°C (°F)	

Industrial Armored Delivery Fiber (optional)

Fiber Length (m)	15 (standard)
Fiber Core Diameter (μ m)	800
Fiber NA	0.15
Fiber Connector	SMA 905

Variable Imager (Abberation Corrected)(optional)

Magnification	1.2x to 1.5x (focussed)
Working Distance (mm)	~60 to 70 nominal
Beam Profile	Top Hat
Length (mm)	~100
Diameter (mm)	~32
Weight	~0.5 kg (1 lb.)

**Beam Profile: 1.2x to 1.5x
Flat Top/Round/Square**

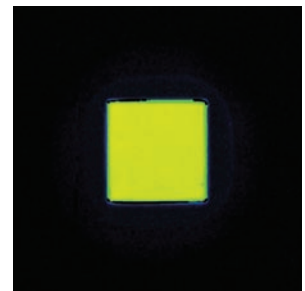
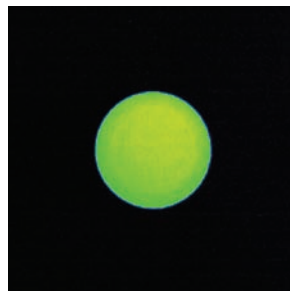

HighLight FAP System

Sub-kW Direct-Diode Laser System

Mechanical Specifications

HighLight FAP 30 and FAP 60

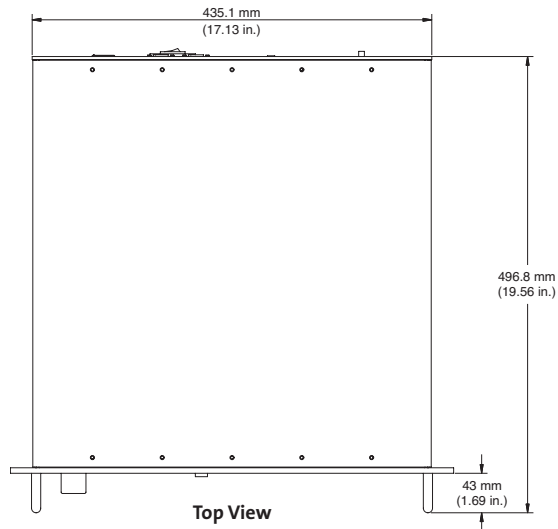

Variable Aberration FAP Corrected Imager

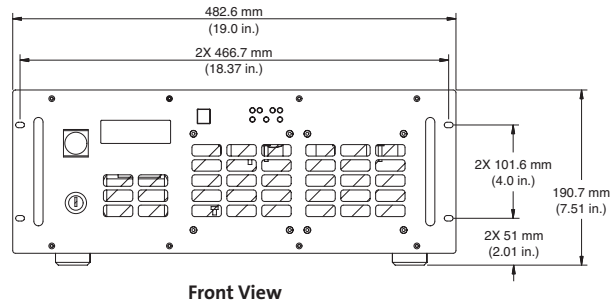
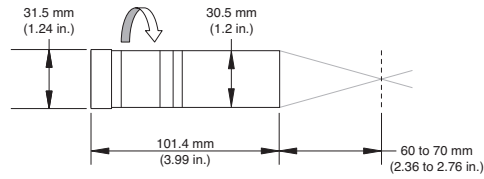

HighLight FAP 100

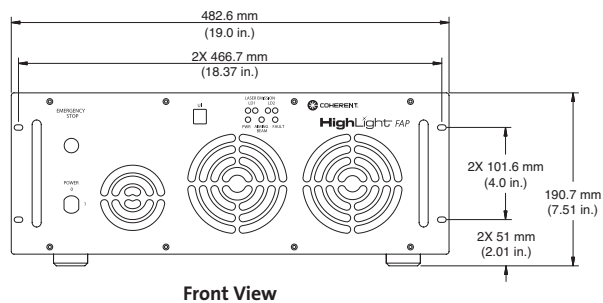
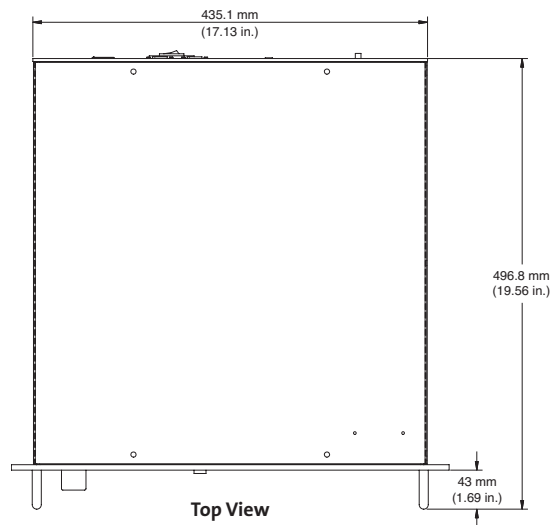

www.Coherent.com

Coherent, Inc.,
 5100 Patrick Henry Drive
 Santa Clara, CA 95054
 phone (800) 527-3786
 (408) 764-4983
 fax (408) 764-4646
 e-mail tech.sales@Coherent.com

Benelux +31 (30) 280 6060
 China +86 (10) 8215 3600
 France +33 (0)1 8038 1000
 Germany/Austria/
 Switzerland +49 (6071) 968 333
 Italy +39 (02) 31 03 951
 Japan +81 (3) 5635 8700
 Korea +82 (2) 460 7900
 Taiwan +886 (3) 505 2900
 UK/Ireland +44 (1353) 658 833

Coherent follows a policy of continuous product improvement. Specifications are subject to change without notice.

Coherent's scientific and industrial lasers are certified to comply with the Federal Regulations (21 CFR Subchapter J) as administered by the Center for Devices and Radiological Health on all systems ordered for shipment after August 2, 1976.

Coherent offers a limited warranty for all HighLight FAP systems. For full details of this warranty coverage, please refer to the Service section at www.Coherent.com or contact your local Sales or Service Representative.

