

# GeoLasHD

Superior Solid Sampling at 193 nm

## Young Zircons, Fluid Inclusions and More

GeoLasHD is the next generation laser ablation system for all-encompassing LA-ICP-MS elemental and isotopic analysis. Powered by the mighty COMPexPro laser, it uniquely combines sturdy high-resolution optical design, expert petrographic microscope and the latest in Full-HD camera technology. The GeoLas EAGLE control software features Full-HD live monitoring of micron-size features and seamless sample surface mapping.

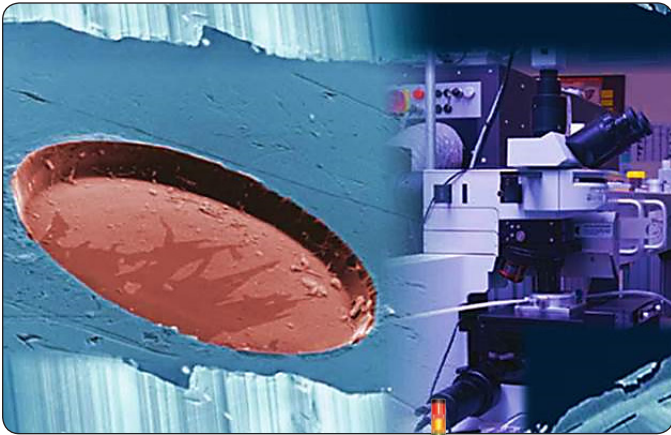

**Superior Reliability & Performance**

### GeoLasHD Features:

- Superior Schwarzschild Ablation
- Novel Full-HD Camera
- GeoLas EAGLE software
- Multi-Format Sample Cell
- Sub-Micron Precision x-y-z-stage

### GeoLasHD Applications:

- Isotope Ratio Determination
- Fluid Inclusion Research
- U/Pb-Age Dating in Zircons
- Marine Sediment Analysis
- 193 nm Multicollector ICP-MS
- Gemstone Fingerprinting

# GeoLasHD

Superior Solid Sampling at 193 nm

## System Specifications

## GeoLasHD

Operating Wavelength (nm)	193
Spot Sizes ( $\mu\text{m}$ )	4 to 160
Optical Resolution ( $\mu\text{m}$ )	1
Beam Homogeneity (%) (1 sigma)	1
Maximum Fluence ( $\text{J}/\text{cm}^2$ )	50
Pulse Stability (% rms)	2
Repetition Rate (Hz)	1 to 100
X,Y-Drive Min. Step Size ( $\mu\text{m}$ )	0.1
Z-Focus Min. Step Size ( $\mu\text{m}$ )	0.1
Dimensions (L x W x H)	2470 x 1142 x 1440 mm (97.24 x 44.96 x 56.69 in.)
Weight	395 kg (870.83 lbs.)
Mains Supply	110/230 VAC, 1 PN, 25/16A

## GeoLasHD Performance

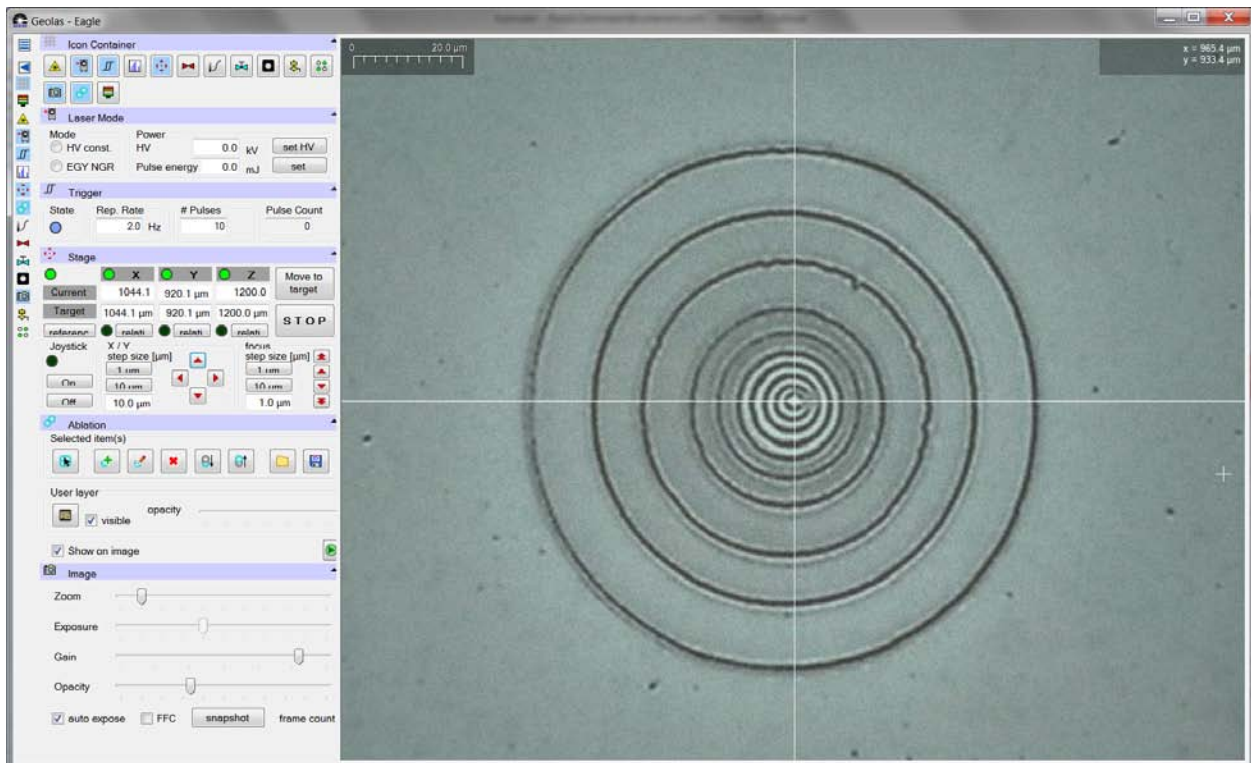

# GeoLasHD

Superior Solid Sampling at 193 nm

## Mechanical Specifications

Front View

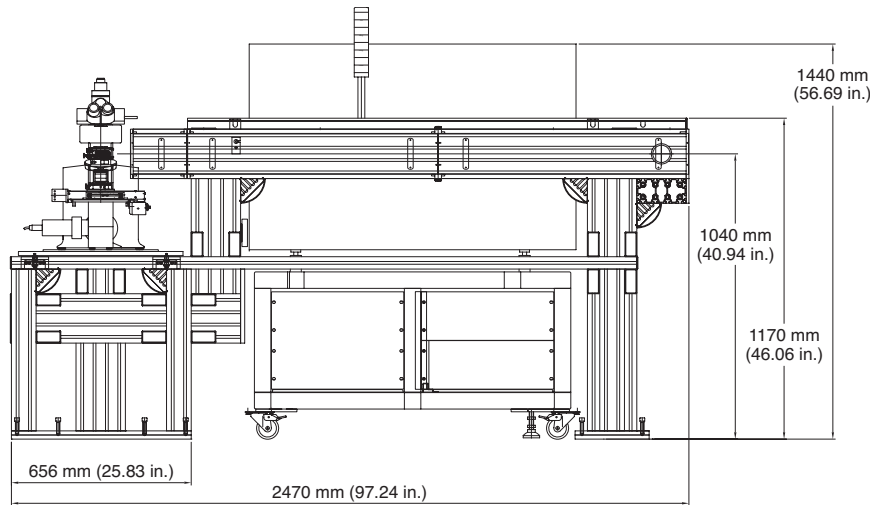

Side View

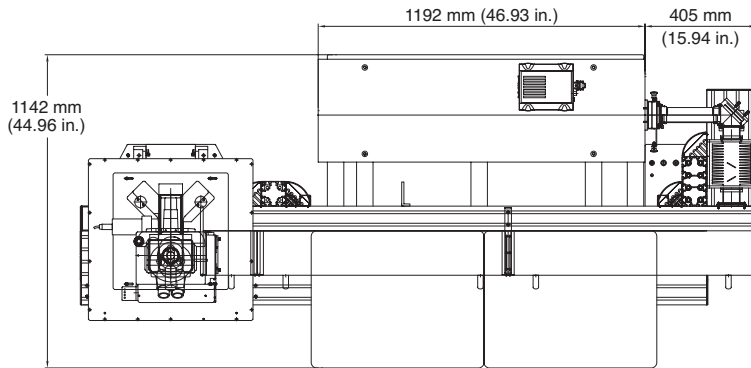
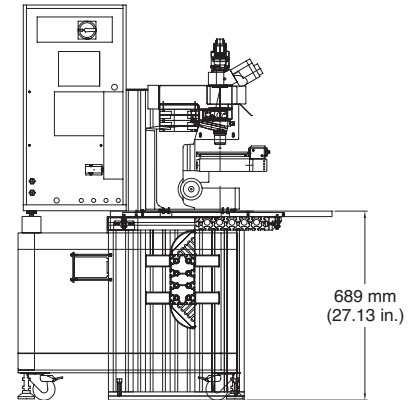

Top View



[www.Coherent.com](http://www.Coherent.com)

### Coherent, Inc.,

5100 Patrick Henry Drive  
 Santa Clara, CA 95054  
 phone (800) 527-3786  
 (408) 764-4983  
 fax (408) 764-4646  
 e-mail [tech.sales@Coherent.com](mailto:tech.sales@Coherent.com)

Benelux	+31 (30) 280 6060
China	+86 (10) 8215 3600
France	+33 (0)1 8038 1000
Germany/Austria/ Switzerland	+49 (6071) 968 333
Italy	+39 (02) 31 03 951
Japan	+81 (3) 5635 8700
Korea	+82 (2) 460 7900
Taiwan	+886 (3) 505 2900
UK/Ireland	+44 (1353) 658 833

Coherent follows a policy of continuous product improvement. Specifications are subject to change without notice.

Coherent's scientific and industrial lasers are certified to comply with the Federal Regulations (21 CFR Subchapter J) as administered by the Center for Devices and Radiological Health on all systems ordered for shipment after August 2, 1976.

Coherent offers a limited warranty for all GeoLasHD systems. For full details of this warranty coverage, please refer to the Service section at [www.Coherent.com](http://www.Coherent.com) or contact your local Sales or Service Representative.

